

Actuator Driven Compact Valves

- **KELMO® Electric Actuators: EA, EAE, ED, ESA, RD and LDP Series**
- **Pneumatic Actuators: C, CS, FBS Series**
- **1/4" to 2" Class 5K/10K/20K Bronze and Stainless Steel Threaded Valves**



Contents

Page

Product coding		01
Production range		02
Valve design and applications		04
Valve flow coefficient		05
Valve materials		05
KITZ 3-way compact ball valves: Flow directional form		05
Seat P-T ratings		06
<KITZ KELMO compact electric actuator series:>		
EA/EAH series	Actuator which was designed exclusively for small size ball valves Many products are prepared and are available for various fluids.	10
EAE series	Spring return type. Two wiring system. Operation time is not so fast unlike solenoid valves so that water hammer is hard to occur. Easy manual operation. Manual lock mechanism.	28
ED series	Actuator for DC12/24V. Available for battery power supply and sequence of measuring equipment. ED12/24-2 is available for vehicle.	30
ES series	Design for build-in apparatus is characteristic. Installing and removing without tools. Light and compact design.	32
RD series	Rotary control type. Suitable for proportional control with high accuracy.	34
LD series	Linear control type. Coolant flow control use of semiconductor production device.	36
<KITZ compact pneumatic actuator series:>		
C · CS/FBS series	Actuator which was designed exclusively for small size ball valves Die-cast aluminum body and double piston mechanism make actuator lightweight and compact. Direct mount type special solenoid valve exclusively use.	39

PRODUCT Coding

Product coding for actuator (On-off control)

EA LB 100 — 1

1
2
3
4

- ① Actuator type
 - EA AC actuator (90° shaft rotation)
 - EAH AC actuator (180° shaft rotation)
 - ED DC actuator (90° shaft rotation)
 - ESA Toolless designed AC actuator (90° shaft rotation)
 - EAE Spring retrn type AC actuator (90° shaft rotation)
- ② Wiring
 - None with cables
 - L with build-in relay for EA series only
 - B with terminal box for EA/EAH/ED/EAE seeries only
 - LB L + B for EA series only
- ③ Power supply
 - 100 AC 100
 - 200 AC 200
 - 12 DC12V
 - 24 DC24V
- ④ Type
 - 1 except EDH series
 - 1.5 for EA/EAH series only
 - 2 except EKSR/ESA/EAE series

Product coding for actuator (Proportional control)

R D P2 24 —

1
2
3
4

- ① Actuator movement
 - R Rotay
 - L Liniar
- ② D DC power supply
- ③ Operation panel
 - P2 without
 - H1 with external output terminal box for RD series only
- ④ DC power supply
 - 24 DC24V

Product coding for actuator (Pneumatic)

CS — 1

1
2

- ① Action
 - C Double action
 - CS Spring return
 - FBS Spring return
- ② Type
 - 1
 - 2 except FBS

Product coding for valve

U T KLH E *

1
2
3
4
5

- ① Body material
 - None Bronze/Brass
 - U Stainless steel
 - 5/10U Stainless steel, wafer type
- ② Valve type
 - T Screwed Ball valve
 - NL Screwed Needle valve
- ③ Design
 - None Standard or Reduced bore
 - F Full bore
 - L Long neck
 - N Horizontal 3-way ball
 - NV/V Vertical 3-way ball
 - G Gland packing design
 - U Male & Female with an Union ring
 - LU L + U
 - AS Uni-body, M5 tapped for panel mounting
 - KS Uni-body, M5 tapped for panel mounting
 - KL Uni-body, Long neck
 - KLAH Uni-body, Long neck, steam service(180°)
 - KLV Uni-body, Long neck, Vertical 3-way ball
 - Q V cut ball
 - LQ L + Q
 - KLQS Uni-body, Long neck, V cut ball
 - W Wafer type, Full bore
- ④ E Valve for actuator exclusive use
- ⑤ M 316SS for U of ②
 - K MLIT building construction standard specifications in Japan
 - X with PPS bracket that is available for low temp (-15°C~+100°C) & lagging
 - <JPF01> Hypatite PTFE seat & PTFE packing for UTGE
 - <JM201> Hot water rinsing & grease is adapted to food use for UTEX

Types EA · EAB

Types EAL · EALB

Types EAH · EAHB

Type EAE

Type ED

Type ES

Types C·CS/FBS

Production range

EA/EAE/ED/ES series (On-off control) KELMO Electric Actuator Driven Threaded Ball Valves

Type	KITZ Fig.	Actuator		Threaded Ball or Needle valves					Page					
		Rotation*	Function	Material	Port	Neck	Bore**	Connection		Size				
EA 100V AC 200V AC	EA100/200-TE	90° B.D.	AC (Basic version)	Bronze	2-way	Short	S.B.	Threaded	3/8" to 2"	11				
	EA100/200-TFE			Bronze or Brass	2-way	Short	F.B.		1/2" to 1 1/2"	12				
	EA100/200-TLE			Bronze	2-way	Long	S.B.		1/2" to 2"	13				
	EA100/200-TNE			Bronze	Horizontal 3-way	Short	S.B.		1/4" to 2"	14				
	EA100/200-TUE			Bronze	2-way	Short	R.B.	M & F Threaded	1/2" to 3/4"	15				
	EA100/200-TLUE			Bronze	2-way	Long	R.B.		1/2" to 3/4"					
	EA100/200-TLEK			Bronze	2-way	Long	S.B.	Threaded	1/2" to 2"	16				
	EA100/200-UTE			Stainless steel	2-way	Short	R.B.		1/4" to 2"	17				
	EA100/200-UTFE			Stainless steel	2-way	Short	F.B.		1/2" to 1 1/2"	18				
	EA100/200-UTGE			Stainless steel	2-way	Short	R.B.		1/4" to 1"	19				
	EA100/200-UTNE			Stainless steel	Horizontal 3-way	Short	R.B.	1/4" to 2"	20					
	EA100/200-5/10UTWE			Stainless steel	2-way	Short	F.B.	Wafer	3/8" to 1"	21				
EAB 100V AC 200V AC	EAB100/200-TE	90° B.D.	EA with terminal box	Bronze	2-way	Short	S.B.	Threaded	3/8" to 2"	22				
	EAB100/200-TFE			Bronze or Brass	2-way	Short	F.B.		1/2" to 1 1/2"					
	EAB100/200-TLE			Bronze	2-way	Long	S.B.	1/2" to 2"						
	EAB100/200-TNE			Bronze	Horizontal 3-way	Short	S.B.	1/4" to 2"						
	EAB100/200-TUE			Bronze	2-way	Short	R.B.	M & F Threaded	1/2" to 3/4"					
	EAB100/200-TLUE			Bronze	2-way	Long	R.B.		1/2" to 3/4"					
	EAB100/200-TLEK			Bronze	2-way	Long	S.B.	Threaded	1/2" to 2"					
	EAB100/200-UTE			Stainless steel	2-way	Short	R.B.		1/4" to 2"					
	EAB100/200-UTFE			Stainless steel	2-way	Short	F.B.		1/2" to 1 1/2"					
	EAB100/200-UTGE			Stainless steel	2-way	Short	R.B.		1/4" to 1"					
	EAB100/200-UTNE			Stainless steel	Horizontal 3-way	Short	R.B.	1/4" to 2"	Wafer		3/8" to 1"			
	EAB100/200-5/10UTWE			Stainless steel	2-way	Short	F.B.	3/8" to 1"						
	EAL 100V AC 200V AC			EAL100/200-TE	90° B.D.	EA with build-in relay	Bronze	2-way	Short		S.B.	Threaded	3/8" to 2"	24
				EAL100/200-TFE			Bronze or Brass	2-way	Short		F.B.		1/2" to 1 1/2"	
EAL100/200-TLE		Bronze	2-way	Long			S.B.	1/2" to 2"						
EAL100/200-TNE		Bronze	Horizontal 3-way	Short			S.B.	1/4" to 2"						
EAL100/200-TUE		Bronze	2-way	Short			R.B.	M & F Threaded	1/2" to 3/4"					
EAL100/200-TLUE		Bronze	2-way	Long			R.B.		1/2" to 3/4"					
EAL100/200-TLEK		Bronze	2-way	Long			S.B.	Threaded	1/2" to 2"					
EAL100/200-UTE		Stainless steel	2-way	Short			R.B.		1/4" to 2"					
EAL100/200-UTFE		Stainless steel	2-way	Short			F.B.		1/2" to 1 1/2"					
EAL100/200-UTGE		Stainless steel	2-way	Short			R.B.		1/4" to 1"					
EAL100/200-UTNE		Stainless steel	Horizontal 3-way	Short			R.B.	1/4" to 2"	Wafer	3/8" to 1"				
EAL100/200-5/10UTWE		Stainless steel	2-way	Short			F.B.	3/8" to 1"						
EALB 100V AC 200V AC		EALB100/200-TE	90° B.D.	EA with terminal box and build-in relay			Bronze	2-way	Short	S.B.	Threaded	3/8" to 2"	24	
		EALB100/200-TFE					Bronze or Brass	2-way	Short	F.B.		1/2" to 1 1/2"		
	EALB100/200-TLE	Bronze			2-way	Long	S.B.	1/2" to 2"						
	EALB100/200-TNE	Bronze			Horizontal 3-way	Short	S.B.	1/4" to 2"						
	EALB100/200-TUE	Bronze			2-way	Short	R.B.	M & F Threaded	1/2" to 3/4"					
	EALB100/200-TLUE	Bronze			2-way	Long	R.B.		1/2" to 3/4"					
	EALB100/200-TLEK	Bronze			2-way	Long	S.B.	Threaded	1/2" to 2"					
	EALB100/200-UTE	Stainless steel			2-way	Short	R.B.		1/4" to 2"					
	EALB100/200-UTFE	Stainless steel			2-way	Short	F.B.		1/2" to 1 1/2"					
	EALB100/200-UTGE	Stainless steel			2-way	Short	R.B.		1/4" to 1"					
	EALB100/200-UTNE	Stainless steel			Horizontal 3-way	Short	R.B.	1/4" to 2"	Wafer	3/8" to 1"				
	EALB100/200-5/10UTWE	Stainless steel			2-way	Short	F.B.	3/8" to 1"						
	EAH 100V AC 200V AC	EAH100/200-TNVE			180° B.D.	EA for 180° turn	Bronze	Vertical 3-way	Short	S.B.	Threaded	1/2" to 1 1/4"		26
		EAH100/200-UTVE					Stainless steel	Vertical 3-way	Short	R.B.		1/4" to 1"		
EAHB 100V AC 200V AC	EAHB100/200-TNVE	180° B.D.	EAH with terminal box	Bronze	Vertical 3-way	Short	S.B.	Threaded	1/2" to 1 1/4"	27				
	EAHB100/200-UTVE			Stainless steel	Vertical 3-way	Short	R.B.		1/4" to 1"					
EAE 100V AC 200V AC	EAE100/200-TE***	90° B.D.	Spring return	Bronze	2-way	Short	S.B.	M & F Threaded	3/8" to 1/2"	29				
	EAE100/200-TNE***			Bronze	Horizontal 3-way	Short	S.B.		1/4" to 1/2"					
	EAE100/200-TUE			Bronze	2-way	Short	R.B.	1/2"						
	EAE100/200-UTE			Stainless steel	2-way	Short	R.B.	1/4" to 1/2"						
	EAE100/200-TKSE***			Brass	2-way	Short	R.B.	1/2" to 3/4"						
ED 12V DC 24V DC	ED12/24-TE	90° B.D.	DC (Basic version) <Terminal box Option>	Bronze	2-way	Short	S.B.	Threaded	3/8" to 2"	31				
	ED12/24-TFE			Bronze or Brass	2-way	Short	F.B.		1/2" to 1 1/2"					
	ED12/24-TNE			Bronze	Horizontal 3-way	Short	S.B.		1/4" to 2"					
	ED12/24-UTE			Stainless steel	2-way	Short	R.B.		1/4" to 2"					
	ED12/24-UTFE			Stainless steel	2-way	Short	F.B.	1/2" to 1 1/2"						
	ED12/24-UTGE			Stainless steel	2-way	Short	R.B.	1/4" to 1"						
	ED12/24-UTNE			Stainless steel	Horizontal 3-way	Short	R.B.	1/4" to 2"						
	ED12/24-5/10UTWE			Stainless steel	2-way	Short	F.B.	3/8" to 1"						
ES 100V AC 200V AC	ESA100/200-TASE	90° B.D.	For compact valves (Basic)	Bronze	2-way	Short	R.B.	Threaded	1/2" to 1"	33				
	ESA100/200-UTASE			Stainless steel	2-way	Short	R.B.		1/2" to 1"					

* Actuator rotation: B.D.=Bi-directional
 ** Bore design: F.B.=Full bore, S.B.=Standard bore, R.B.=Reduced bore
 *** 1/2" of TE & TNE and 3/4" of TKSE: 5K service

RD/LD series (Proportional control) KELMO Electric Actuator Driven Threaded Ball & Needle Valves

Type	KITZ Fig.	Actuator		Threaded Ball or Needle valves						Page
		Rotation*	Function	Material	Port	Neck	Bore**	Connection	Size	
RD 24V DC	RDP224-TE	90° B.D.	DC 24V	Bronze	2-way	Short	S.B.	Threaded	3/8" to 1 1/2"	35
	RDP224-TFE			Brass	2-way	Short	F.B.		1/2" to 1 1/4"	
	RDP224-UTE			Stainless steel	2-way	Short	R.B.		1/4" to 2"	
	RDP224-UTFE			Stainless steel	2-way	Short	F.B.		1/2" to 1 1/2"	
	RDP224-TQE***			Bronze	2-way	Short	S.B.		3/8" to 1 1/2"	
	RDP224-TKLQSE***			Bronze	2-way	Long	R.B.		1/2" to 1"	
	RDP224-UTQE***			Stainless steel	2-way	Short	R.B.		1/4" to 2"	
	RDP224-TKLVE			Bronze	Vertical 3-way	Long	R.B.		1/2" to 1 1/4"	
	RDP224-UTKLVE			Stainless steel	Vertical 3-way	Long	R.B.		1/2" to 1"	
	RDH124-TE(N)			Bronze	2-way	Short	S.B.		3/8" to 1 1/2"	
	RDH124-TFE(N)			Brass	2-way	Short	F.B.		1/2" to 1 1/4"	
	RDH124-TNE(N)			Bronze	Horizontal 3-way	Short	S.B.		3/8" to 1 1/4"	
	RDH124-UTE(N)			Stainless steel	2-way	Short	R.B.		1/4" to 2"	
	RDH124-UTFE(N)			Stainless steel	2-way	Short	F.B.		1/2" to 1 1/4"	
	RDH124-TQE(N)***			Bronze	2-way	Short	S.B.		3/8" to 1 1/2"	
	RDH124-TKLQSE(N)***			Bronze	2-way	Long	R.B.		1/2" to 1"	
	RDH124-UTQE(N)***			Stainless steel	2-way	Short	R.B.		1/4" to 2"	
	RDH124-TKLVE(N)			Bronze	Vertical 3-way	Long	R.B.		1/2" to 1 1/4"	
RDH124-UTKLVE(N)	Stainless steel	Vertical 3-way	Long	R.B.	1/2" to 1"					
LDP 24V DC	LDP224-UNLE	Linear	DC 24V	Stainless steel	Needle2-way	-	-		1/4" to 3/8"	37

* Actuator rotation: B.D.=Bi-directional
 ** Bore design: F.B.=Full bore, S.B.=Standard bore, R.B.=Reduced bore
 *** V cut ball

C · CS/FBS Series pneumatic Actuators Driven Threaded Ball Valves

Type	KITZ Fig.	Actuator		Threaded Ball or Needle valves						Page	
		Rotation*	Function	Material	Port	Neck	Bore**	Connection	Size		
C	C-TE	90° B.D.	Double action	Bronze	2-way	Short	S.B.	Threaded	3/8" to 2"	41	
	C-TFE			Bronze or Brass	2-way	Short	F.B.		1/2" to 1 1/2"	42	
	C-TLE			Bronze	2-way	Long	S.B.		1/2" to 2"	43	
	C-TNE			Bronze	Horizontal 3-way	Short	S.B.		1/4" to 2"	44	
	C-TUE			Bronze	2-way	Short	R.B.		M & F Threaded	1/2" to 3/4"	45
	C-UTE			Stainless steel	2-way	Short	R.B.		Threaded	1/4" to 2"	46
	C-UTFE			Stainless steel	2-way	Short	F.B.			1/2" to 1 1/2"	47
	C-UTGE			Stainless steel	2-way	Short	R.B.			1/4" to 1"	48
	C-UTNE			Stainless steel	Horizontal 3-way	Short	R.B.			1/4" to 2"	49
	C-5/10UTWE			Stainless steel	2-way	Short	F.B.		Wafer	3/8" to 1"	50
	C-UTKLAHE <J0J05>			Stainless steel	2-way	Long	R.B.		Threaded	1/2" to 1"	51
	CS / FBC			CS/FBS-TE	90° B.D.	Spring return	Bronze		2-way	Short	S.B.
CS/FBS-TFE		Bronze or Brass	2-way	Short			F.B.	1/2" to 1 1/2"	42		
CS/FBS-TLE		Bronze	2-way	Long			S.B.	1/2" to 2"	43		
CS/FBS-TNE		Bronze	Horizontal 3-way	Short			S.B.	1/4" to 2"	44		
CS-TUE		Bronze	2-way	Short			R.B.	M & F Threaded	1/2" to 3/4"	45	
CS/FBS-UTE		Stainless steel	2-way	Short			R.B.	Threaded	1/4" to 2"	46	
CS/FBS-UTFE		Stainless steel	2-way	Short			F.B.		1/2" to 1 1/2"	47	
CS/FBS-UTGE		Stainless steel	2-way	Short			R.B.		1/4" to 1"	48	
CS/FBS-UTNE		Stainless steel	Horizontal 3-way	Short			R.B.		1/4" to 2"	49	
CS/FBS-5/10UTWE		Stainless steel	2-way	Short			F.B.	Wafer	3/8" to 1"	50	
CS-UTKLAHE <J0J05>		Stainless steel	2-way	Long			R.B.	Threaded	1/2" to 1"	51	

* Actuator rotation: B.D.=Bi-directional
 ** Bore design: F.B.=Full bore, S.B.=Standard bore, R.B.=Reduced bore

Types EA · EAB
 Types EAL · EALB
 Types EAH · EAHB
 Type EAE
 Type ED
 Type ES
 Types C-CS/FBS

KITZ 5K/10K/20K Compact Valves

Valve design features

- Convenient size range from 1/4" through 2".
- Integral actuator mounting pads enabling easy mounting or dismantling of actuators for speedy maintenance.
- Tight contact between PTFE ball seats and high precision machined balls for leakage-free service.
- Stems, made of high strength brass, are used for longer service life.
- Choice of materials: Stainless steel for corrosion resistant service, or brass and bronze for general W.O.G. service.

Valve design specifications

Threaded ends:	JIS B 0203
Union ends:	JIS B 2301
Maximum service pressure:	1.0 MPa TKE and TKSE for 3/4" and larger, 5UTWE: 0.5 MPa TLEK, UTKLEM & UTKLVEM: 2.0MPa
Seat P-T rating:	See Page 6 & 7

Ball & Needle valve design and applications

Fig.	Class	Body	Bore	Neck	Application	Remarks		
TE	10K	CAC406	SB	Short	On-off control of water, oil, and gas			
TFE			FB					
TLE			10/5K	C3771	SB	Long	Insulation*	
TNE					Short		Instantaneous change (Horizontal 3-way)	
TUE					RB	Long	Female & male (uni-body with union nipple) threaded ends***	
TLUE						Long	Insulation*, Female & male (uni-body with union nipple) threaded ends***	
TKSE	10K	CAC406	SB	Short	Uni-body, M5 tapped for panel mounting	for EAE		
TNVE					Instantaneous change (Vertical 3-way)	for EAH		
TASE			RB	Uni-body, M5 tapped for panel mounting	for ESA			
TQE				V cut ball, proportional control****	For RD			
TLQE			RB	Long	Insulation*, V cut ball, proportional control****	For RD		
TKLASE					Uni-body, Insulation*, steam service (150°C)	for EKSR		
TKLQSE					Uni-body, Insulation*, V cut ball, proportional control for steam	For RD		
TKLVE					Uni-body, Insulation*, Instantaneous change (Vertical 3-way), proportional control****	For RD		
TLEK			20K	SB	Insulation*, 2.0MPa service			
UTE			10K	CF8M	RB	Short	Uni-body	RoHS
UTEX							Uni-body, with PPS bracket that is available for low temp (-15°C~ +100°C) & lagging	
UTEX<JM201>					Hot water rinsing & grease is adapted to food use for UTEX			
UTFE	FB	On-off control of water, oil, and gas			RoHS			
UTGE	RB	Uni-body, Gland packing design (Retightening possible)**			RoHS			
UTGE<JPF01>		Uni-body, Gland packing design (Retightening possible)**, Hypatipite PTFE seat			RoHS			
UTNE		Uni-body, Instantaneous change (Horizontal 3-way)			RoHS			
5UTWE	5K	CF8			FB	Uni-body, Wafer type, Easy maintenance	RoHS	
10UTWE	10K	CF8			RB	Short	Uni-body, Instantaneous change (Vertical 3-way)	RoHS, for EAH
UTVE							Uni-body, M5 tapped for panel mounting	RoHS, for ESA
UTASE			RB	Long	Uni-body, V cut ball, proportional control****	RoHS, for RD		
UTQE					Uni-body, Insulation*, steam service (150°C), cavity pressure relief, uni-directional	for EKSR		
UTKLASE					Uni-body, Insulation*, steam service (180°C), cavity pressure relief, uni-directional			
UTKLAHE					Uni-body, Insulation*, 2.0MPa service, proportional control****	For RD		
UTKLE(N)			20K	CF8M	RB	Long	Uni-body, Insulation*, 2.0MPa service, Instantaneous change (Vertical 3-way), proportiona control****	For RD
UTKLEM(N)								For RD
UTKLVE								RoHS, for RD
UTKLVEM			10K	CF8M /316SS	—	Short	Needle valve, proportional control****	RoHS, for RD
UNLE						For LD		

* for thermal isolation

** High temperature service(150°C). Don't install where can't maintain

*** Easy installation

**** for water, oil and gas

Bore design (API 608): FB=Full bore, SB=Standard bore (Single reduced bore), RB=Reduced bore (Double reduced bore)
JIS B0203 of BC/BS ball valves: The length of useful threads & the positions of gauge planes are built on KITZ standard.

Applications

Automated on-off or 3-way flow control in HVAC service handling water, oil, gas and air (by brass and bronze valves) or in light load industrial processes for pharmaceutical, fine chemical, petro-chemical, food, beverage, textile and other general industries.

Precautions

- ① No application to fluids including powders, dirt or sands.
- ② Contact KITZ or its local distributors for technical advice on application to:
 - Fluid of high viscosity, steam or vacuum.
 - Velocity of 3 m/s or faster.
 - Service with concern of an extraordinary pressure rise of line fluid or a variation of fluid temperature higher than 60°C.
 - For voltages other than KITZ standard specification.
 - Use of equipment that put human lives at risk.

Valve flow coefficient (Cv for fully opened valves)

KITZ Fig.	Size (inch)	1/4	3/8	1/2	3/4	1	1 1/4	1 1/2	2
TE · TLE* · TLEK*		—	2.1	5.6	15	27	45	85	120
TNE		0.5	1	2.2	4	7	9	15	25
TUE · TLUE		—	—	3.4	6.2	—	—	—	—
TKE · TKSE*		0.9	2.4	3.4	6.1	—	—	—	—
TNVE		—	—	3	7.3	13	17	—	—
TASE		—	—	5	8	15	—	—	—
UTE · UTGE* · UTASE* · UTEX		2.2	2.3	4.3	8	12	18	32	53
UTNE		0.5	1.3	2.2	3.9	6.7	9.4	15	25
TFE · UTFE		—	—	22	46	74	132	225	—
5/10UTWE		—	8	22	46	75	—	—	—
UTVE		0.5	1	2.2	3.9	7	—	—	—
TQE		—	1.5	2.6	6.6	11	16	28	—
TKLQSE* · UTQE		0.4	1	2.1	3.8	6.7	10	15	21
UTKLE(N)		—	—	4.3	8	12	—	—	—
TKLVE · UTKLVE(M)		—	—	1.9	3.7	6.4	9.7	15	24
TKLASE · UTKLAHE · UTKLASE		—	—	4.3	8	12	—	—	—
UNLE		0.02~0.2	0.03~0.6	0.06~1.2	0.08~0.16	0.15~3.0	—	—	—

* TLE/TLEK: 1/2 ~ , TKSE: ~ 3/4, UTGE: ~ 1, UTASE/TKLQSE: 1/2 ~ 1, TKLQSE: 1/2 ~ 2

Valve materials

Parts name	Fig	TQE	TLQE	TKLQSE	UTQE	TKLVE	UTKLVE(M)	UTKLE	UTKLAHE	UTEX
Body		CAC406	CAC406	CAC406	SCS14A	CAC406	SCS13A(14A)	SCS13A	SCS13A	SCS14A
Cap		C3771	CAC406	—	—	—	—	—	—	—
Stem		C6782BD*	C6782BD*	SUS304	SUS316*	SUS304	SUS304/316*	SUS304*	SUS304*	SUS316
Ball		SCS13A	SCS13A	SCS14A	SCS14A	—	SUS304/316	SUS304	SUS316	SUS316
Insert		—	—	CAC406C	SUS316/304	CAC406C	SUS304/316	SUS304/316	SCS14A	SUS316
Ball seat		PTFE	PTFE	PEEK	PTFE	C/F PTFE	C/F PTFE	C/F PTFE	Hypatite	PTFE
O-ring		FKM	FKM	FKM	FKM	FKM	FKM	FKM	FKM	FKM
Thrust washer		RPTFE	RPTFE	RPTFE	RPTFE	G/F PTFE	G/F PTFE	G/F PTFE	G/F PTFE	RPTFE
Stem bearing		G/F PTFE	G/F PTFE	PTFE	G/F PTFE	G/F PTFE	PTFE · G/F PTFE	PTFE	—	G/F PTFE

* Cr plating

Valve material except the above, please refer to each page.

KITZ 3-way Compact Ball Valves: Change of Flow Directional Form

KITZ horizontal 3-way ball valves are principally used for quick change of flow direction. Also 3-way ball valves can be used for the simplification of piping systems as shown in Fig. 1.

KITZ Fig. TNE, TNVE, UTNE and UTVE 3-way ball valves are provided with L-port and double face seating design for change of flow direction between Form 1 and 2. It should be noted that, if the line pressure of the closed bore is higher than that of the open bores, a small rate of fluid leakage may occur from the closed bore. (Fig. 2)

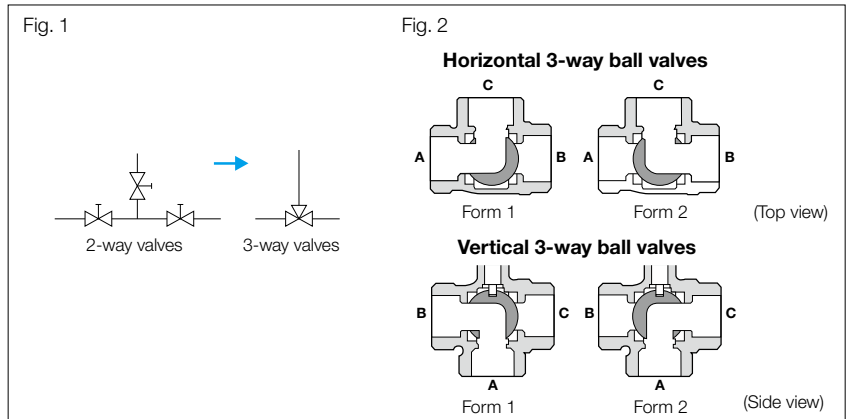

KITZ 3-way Compact Ball Valves: Flow Directional Form before Shipment

Shipment shall be made with the flow directional form fixed as illustrated here. (Fig. 3)

Location of cord connectors (top view):

The location of the cord connector for an actuator is also arranged as below:

Horizontal 3-way: Size 1 & 1.5: Right hand side
 Size 2: Diagonally forward right

Vertical 3-way: Size 1: Right hand side
 Size 2: Diagonally forward left

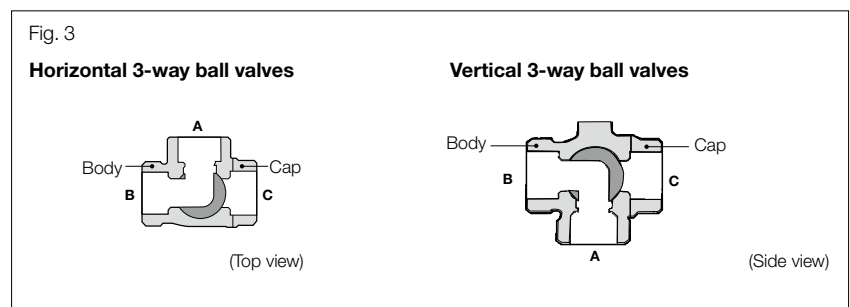

Types EA · EAB

Types EAL · EALB

Types EAH · EAHB

Type EAE

Type ED

Type ES

Types C-CS/FBS

seat pressure-temperature ratings

Valve: **TE · TFE · TLE · TNE · TUE · TLUE · TNVE · TQE · TLQE · UTFE · UTNE · 5/10UTWE · UTVE · UTQE**

- Fluid: water, oil, gas (unfrozen)
- Ball seat: PTFE (Standard)
- O-ring: FKM (Standard)

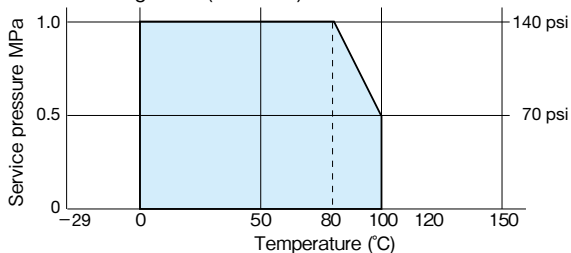

Valve: **UTGE**

- Fluid: water, oil or gas (unfrozen)
- Ball seat: reinforced PTFE
- Gland packing: Flexible graphite+PTFE braided packing

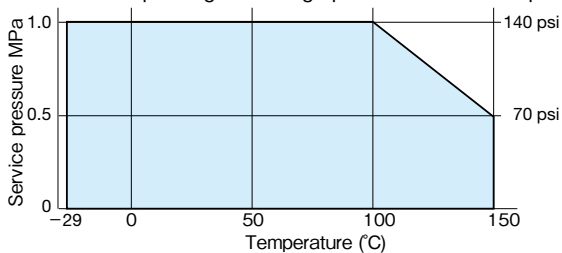

Valve: **TASE · UTASE**

- Fluid: water, oil, gas (unfrozen)
- Ball seat: PTFE (standard)
- O-ring: FKM (standard)

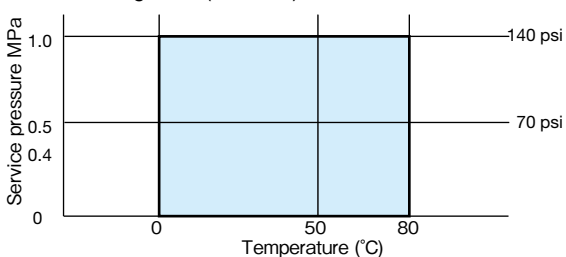

for saturated steam

Valve: **TE · TFE · TLE · TNE · TUE · TLUE · TNVE · TQE · TLQE · UTE · UTFE · UTNE · 5/10UTWE · UTVE · UTQE**

- Fluid: water, oil, gas (unfrozen) or saturated steam
- Ball seat: reinforced PTFE (Option*)
- O-ring: FKM (Option*)

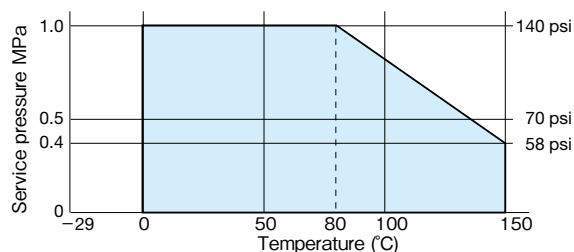

Valve: **TKSE**

- Fluid: water, oil or gas (unfrozen)
- Ball seat: PTFE
- O-ring: FKM

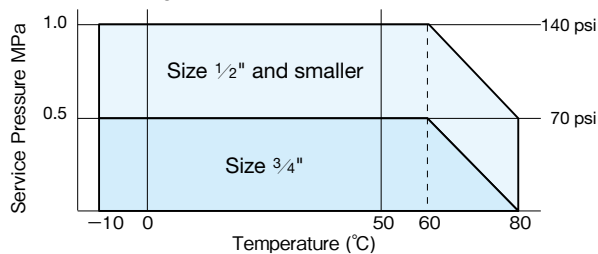

*Specify these materials in your order for the P-T ratings covered by the graph shown above, except for 1 1/2" and 2". Standard materials are only available for these sizes.

Note: • Serviceable ambient temperature depends on the design of actuators. Refer to the information given for each of actuators introduced in this catalog.

• Do NOT install UTGE with gland packing into a position where maintenance is not possible.

seat pressure-temperature ratings

Valve: TKLQSE

- Fluid: saturated steam
- Ball seat: PEEK
- O-ring: FKM for steam service

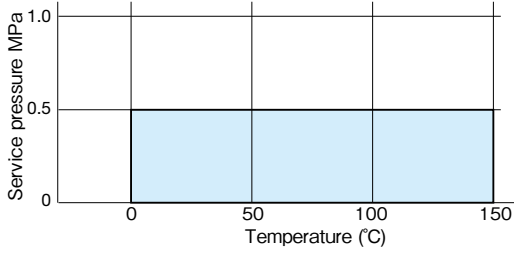

Valve: UTKLAHE

- Fluid: saturated steam
- Ball seat: Hypatite PTFE
- O-ring: FKM for steam service

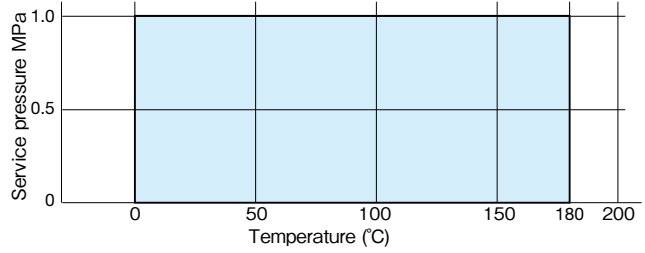

Valve: UNLE

- Fluid: water, oil, gas
- Ball seat: SUS316
- O-ring: FKMt•NBR

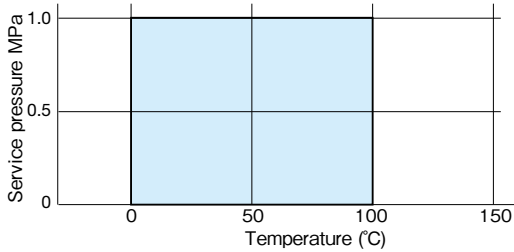

Valve: TKLQSE, TLEK, UTKLVE(M), UTKLE(M)

- Fluid: water, oil, gas
- Ball seat: Reinforced PTFE
- O-ring: FKM

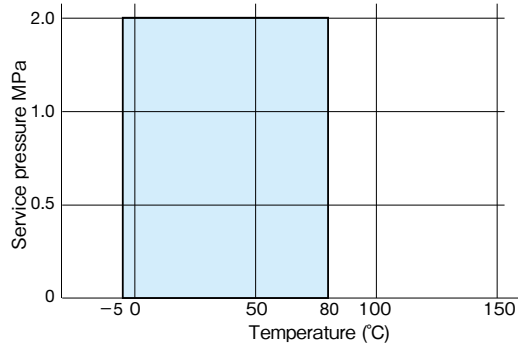

* Max.ΔP: 0.4MPa. ΔP ratio (=ΔP/P1): Less than 0.5

* Max.ΔP: 1.0MPa

Valve: UTEX

- Fluid: water, oil, gas
- Ball seat: PTFE
- O-ring: FKM

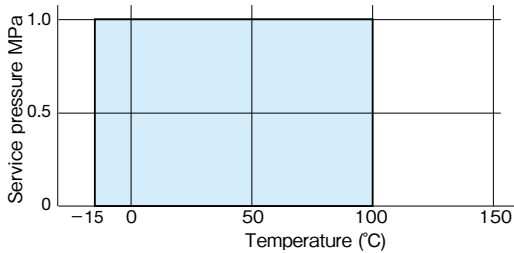

Types EA · EAB

Types EAL · EALB

Types EAH · EAHB

Type EAE

Type ED

Type ES

Types C·CS/FBS

KITZ KELMO® Electric Actuators

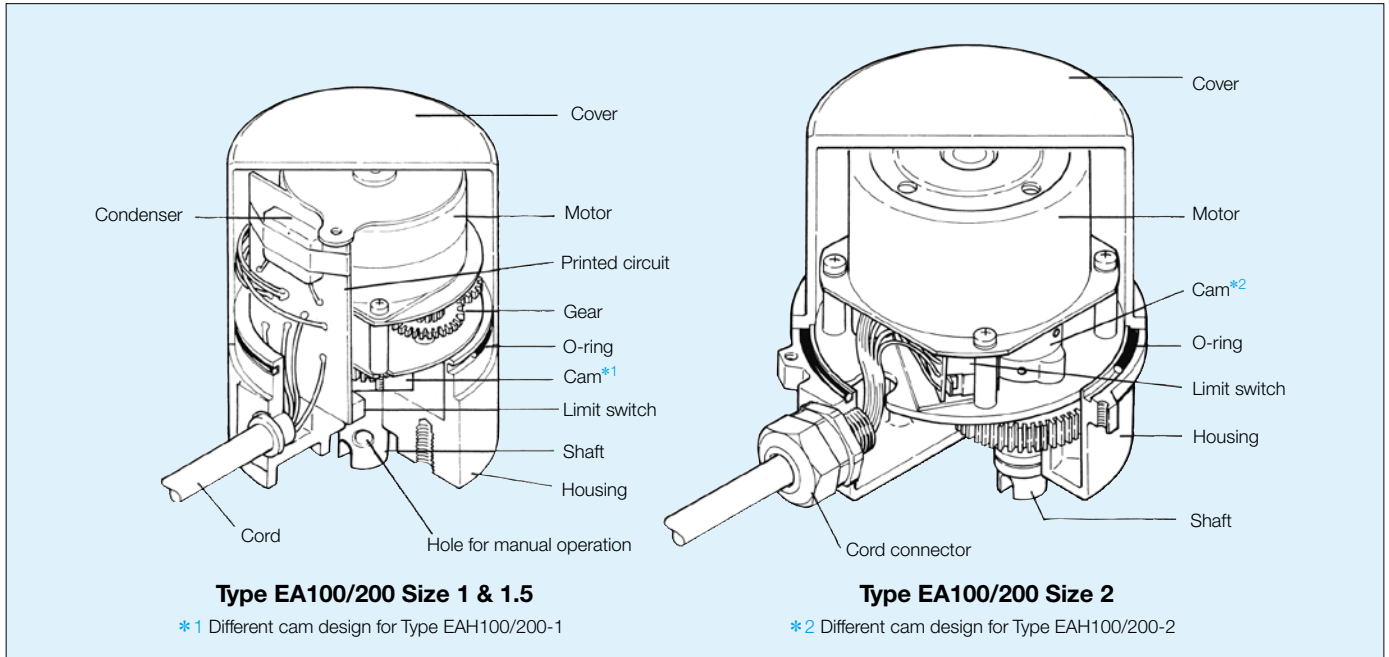

General design features

- Compact size and light weight with die-cast aluminum housing and powerful miniature motor for economy and handling ease.
- Simple mechanism with minimized number of component parts for high durability and trouble-free service.
- Free from concerns common with conventional solenoid valves such as water hammer, pressure loss, and restricted flow direction.
- All-weather-type design for outdoor service. (Avoid exposure to direct sunlight)
- Availability of manual operation in case of electric failure.
- Versatile applications by means of optional built-in relay circuit for parallel drive, terminal boxes and 180° rotary mechanism for 3-way flow direction.
- Safety provision to protect the motor from overheat damage caused by accidental overload.
- Factory-made actuator-to-valve assembly for off-the-shelf supply.

Compact KELMO® actuators: power sources and functional features

Type of actuator	* Power source	Functional features	
EA Series	100/200 V AC (50/60 Hz)	EA100/EA200	90° bidirectional rotation
		EAB100/EAB200	90° bidirectional rotation/Terminal box
		EAL100/EAL200	90° bidirectional rotation/Built-in relay
		EALB100/EALB200	90° bidirectional rotation/Built-in relay/Terminal box
		EAH100/EAH200	180° bidirectional rotation
		EAHB100/EAHB200	180° bidirectional rotation/Terminal box
EAE Series	100/200 V AC (50/60 Hz)	EAE100/EAE200	90° bidirectional rotation/Spring-return
ED Series	12/24 V DC	ED12/ED24	90° bidirectional rotation/Parallel drive
ES Series	100/200 V AC (50/60 Hz)	ESA100/ESA200	90° bidirectional rotation

* Optional Specification (EA Series)

AC110V (50/60Hz)	AC220V (50/60Hz)
AC115V* (50/60Hz)	AC230V* (50/60Hz)
AC120V (50/60Hz)	AC240V (50/60Hz)

*Fluctuation +5%~−10%
 Others: ±10%

Types EA · EAB

Types EAL · EALB

Types EAH · EAHB

Type EAE

Type ED

Type ES

Types C-CS/FBS

Type EA and EAB Electric Actuators/Class 10K Bronze or Stainless Steel Ball Valves

100/200V AC 50/60Hz

■ **90° bidirectional rotation**

■ **Factory assembled terminal box for easier installation of actuators (EAB)**

Type EA and EAB actuator design specifications

Specification	Type	EA100-1 EAB100-1	EA200-1 EAB200-1	EA100-1.5 EAB100-1.5	EA200-1.5 EAB200-1.5	EA100-2 EAB100-2	EA200-2 EAB200-2
Power source 50/60Hz		100V AC±10%	200V AC±10%	100V AC±10%	200V AC±10%	100V AC±10%	200V AC±10%
Rated current		90mA	50mA	90mA	50mA	100mA	50mA
Max. power consumption		9W	10W	9W	10W	10W	
Valve closing time 90°	50Hz	Approx. 6 s		Approx. 12 s		Approx. 15 s	
	60Hz	Approx. 5 s		Approx. 10 s		Approx. 13 s	
Max. output torque		1.9N·m		3.9N·m		9.8N·m	
Rated time		Continuous					
Insulation class		JIS Class E					
Sensitive switch contact capacity		125V AC 2A (Resistance load)				125V AC 2A (Resistance load)	
		250V AC 0.6A (Resistance load)				250V AC 2A (Resistance load)	
Position limit switch		One unit each for opening/closing (Voltage output)					
Insulation strength		1500V AC (1 min. interval)					
Insulation resistance		Minimum 10MΩ (500V DC)					
Standard protection		All weather type (for outdoor use, avoid exposure to direct sunlight) IP56 (IEC60529)					
Ambient temperature		-20°C to +50°C					
Mounting position		Vertical to horizontal					
Wiring		Vinyl cabtyre cord with five cores, 700mm in length					
		0.3mm ²				0.5mm ²	
Lubrication		Grease					
Overload protection		Impedance protection					
Coating color		Housing: black Cover: light blue					

Note: Contact KITZ for technical advice when the service conditions differ from the above.

Type EA actuator circuit diagrams (with the valve fully closed)

EA100/200 Size 1 to 2

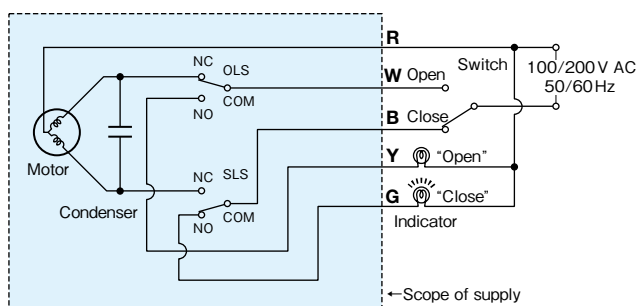

● Wire color: **R** red **W** white **B** black **Y** yellow **G** green

● Actuator rotates:

R-W: counter-clockwise to fully open the valve

R-B: clockwise to fully close the valve

● Limit switches activate:

OLS: on fully opening the valve (R-W: off W-Y: on)

SLS: on fully closing the valve (R-B: off B-G: on)

Note: For all sizes of Type EAB100/200, the terminals are numbered 1, 2, 3, 4 and 5 in place of R, W, B, Y and G, respectively.

Note: ● When two or more actuators are operated by a single switch, ensure to prevent unintended current flow by using relay contacts.

● Auxiliary devices, such as lamps or relays, where minute current is used, may cause failure in the contacts of limit switches. Consult KITZ for such applications.

Type EA Electric Actuators/Class 10K Bronze Ball Valves

Fig. EA100/200-TE

Actuator size: 1 and 1.5
Valve size: 3/8" to 1" (Standard bore)

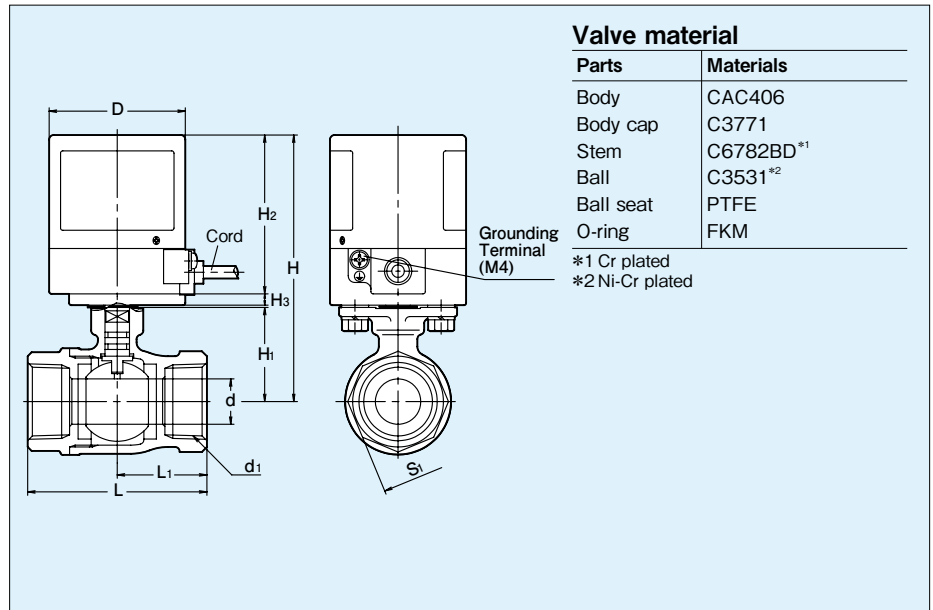

Dimensions

(mm)

Valve Size (inch)	d	d ₁	H	H ₁	L	L ₁	S ₁	Actuator			
								H ₂	H ₃	D	Type
3/8	7.5	Rc3/8	104	28	46	22	22	70	5	60	EA100/200-1
1/2	10	Rc1/2	109.5	33.5	65	32.5	28				
3/4	15	Rc3/4	113.5	37.5	68	34	34				
1	20	Rc1	117.5	41.5	79	39.5	41				

Fig. EA100/200-TE

Actuator size: 2
Valve size: 1/4" to 2" (Standard bore)

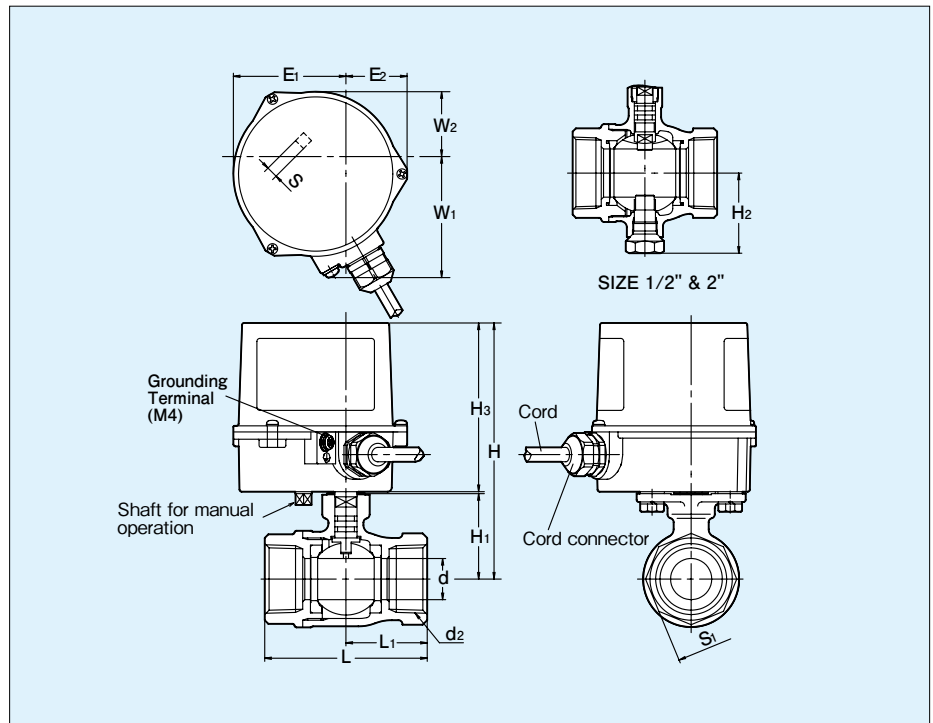
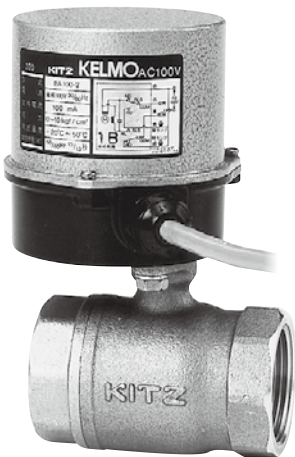

Dimensions

(mm)

Valve Size (inch)	d	d ₁	H	H ₁	H ₂	L	L ₁	S ₁	Actuator						
									H ₃	E ₁	E ₂	W ₁	W ₂	S	Type
1/4	25	Rc1/4	128.5	45.5	—	86	43	50	82	54.5	30	59	31.5	5.5	EA100/200-2
1/2	32	Rc1/2	142.5	59.5	53.5	96	48	56							
2	40	Rc2	148.5	65.5	60	109	54.5	68							

Type EA Electric Actuators/Class 10K Bronze or Brass Ball Valves

Fig. EA100/200-TFE

Actuator size: 1.5
Valve size: 1/2" and 3/4" (Full bore)

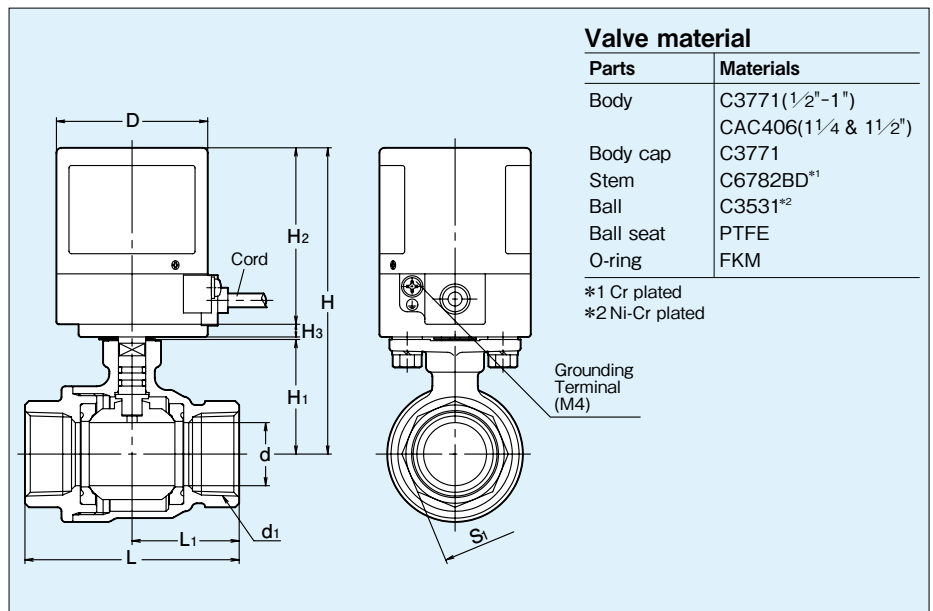

Dimensions

Valve Size (inch)	d	d ₁	H	H ₁	L	L ₁	S ₁	Actuator			
								H ₂	H ₃	D	Type
1/2	15	Rc1/2	113.5	37.5	63	31.5	26	70	5	60	EA100/200-1.5
3/4	20	Rc3/4	117.5	41.5	73	36.5	32				

Fig. EA100/200-TFE

Actuator size: 2
Valve size: 1" to 1 1/2" (Full bore)

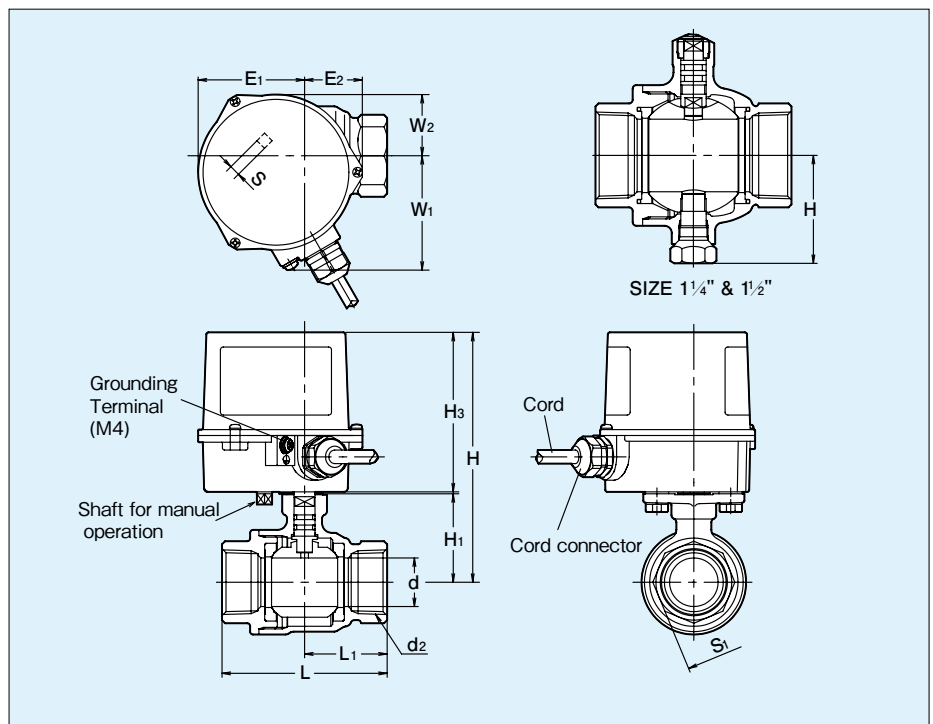
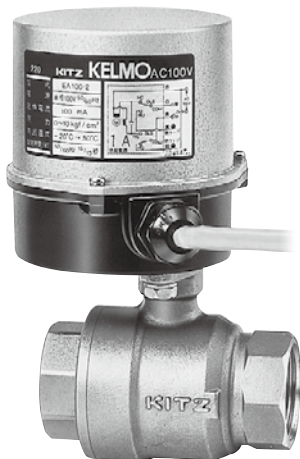

Dimensions

Valve Size (inch)	d	d ₁	H	H ₁	H ₂	L	L ₁	S ₁	Actuator						
									H ₃	E ₁	E ₂	W ₁	W ₂	S	Type
1	25	Rc1	128.5	45.5	—	85	42.5	39	82	54.5	30	59	31.5	5.5	EA100/200-2
1 1/4	32	Rc1 1/4	142.5	59.2	53.5	98	49	50							
1 1/2	40	Rc1 1/2	148.5	65.5	59.5	108	54	56							

Type EA Electric Actuators/Class 10K Long Neck Bronze Ball Valves

Fig. EA100/200-TLE

Actuator size: 1 and 1.5
Valve size: 1/2" to 1" (Standard bore)

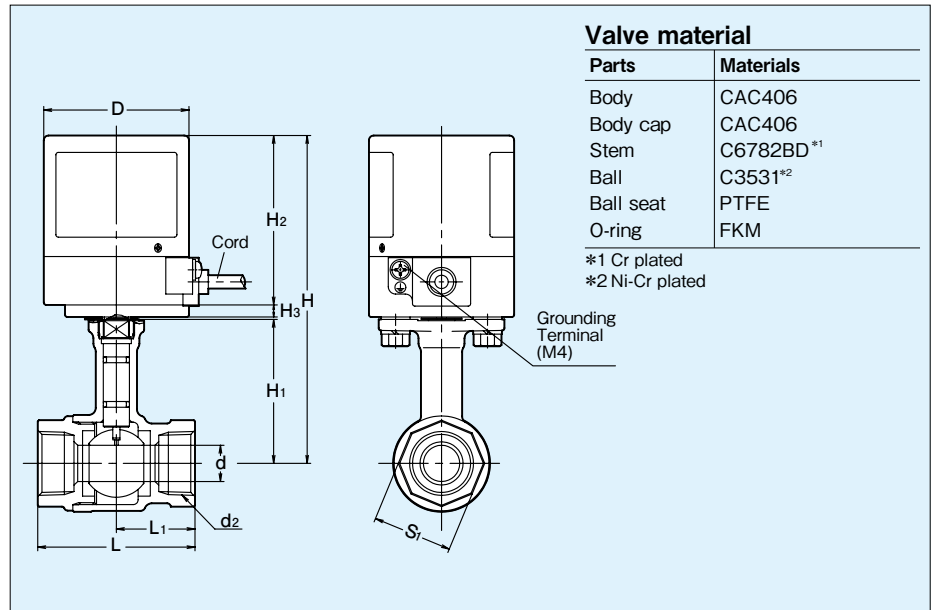

Dimensions

(mm)

Valve Size (inch)	d	d ₁	H	H _i	L	L ₁	S ₁	Actuator			
								H ₂	H ₃	D	Type
1/2	10	Rc1/2	132	56	56	28	27	70	5	60	EA100/200-1
3/4	15	Rc3/4	136.5	60.5	65	32.5	33				EA100/200-1.5
1	20	Rc1	140	64	78	39	41				

Fig. EA100/200-TLE

Actuator size: 2
Valve size: 1 1/4" to 2" (Standard bore)

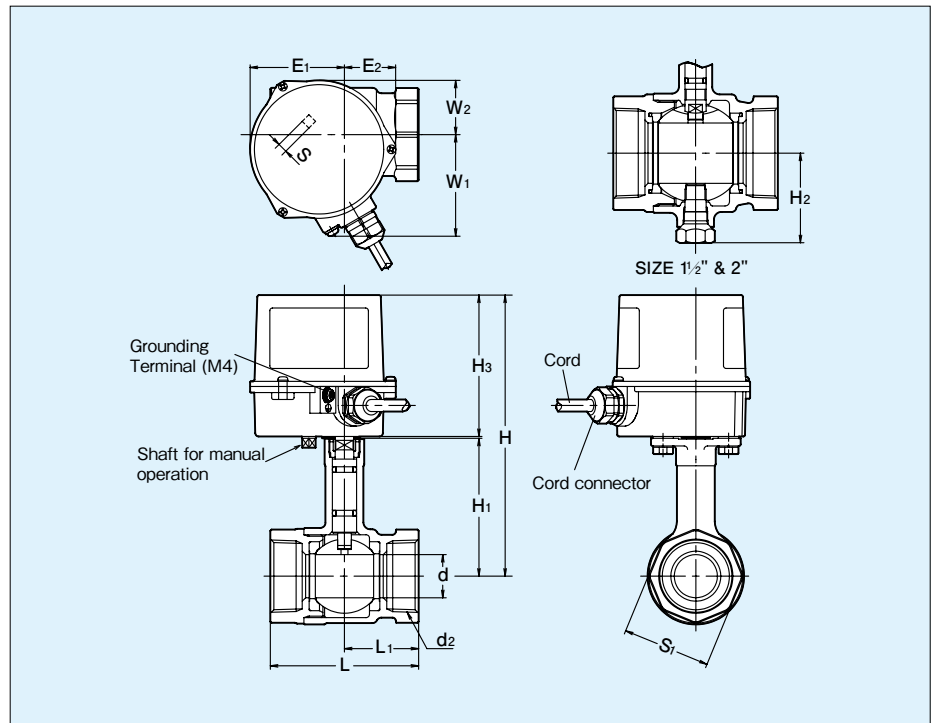
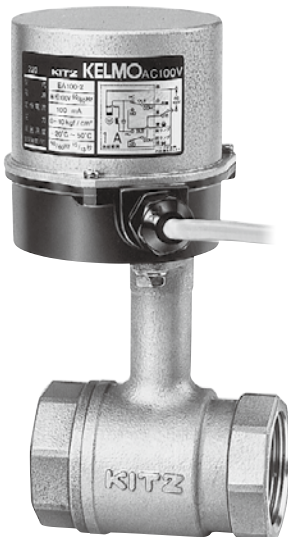

Dimensions

(mm)

Valve Size (inch)	d	d ₁	H	H _i	H ₂	L	L ₁	S ₁	Actuator						
									H ₃	E ₁	E ₂	W ₁	W ₂	S	Type
1 1/4	25	Rc1 1/4	163	80	—	86	43	51	82	54.5	30	59	31.5	5.5	EA100/200-2
1 1/2	32	Rc1 1/2	166	83	53.5	96	48	58							
2	40	Rc2	173	90	60	109	54.5	71							

Type EA Electric Actuators/Class 10K Horizontal 3-way Bronze Ball Valves

Fig. EA100/200-TNE

Actuator size: 1 and 1.5
Valve size: 1/2" to 1" (Standard bore)

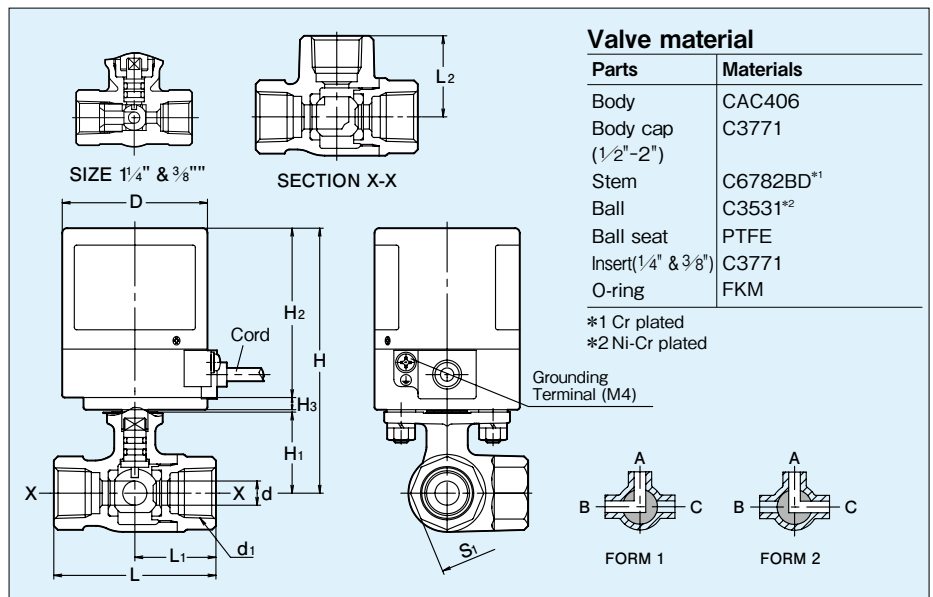

Note: Refer to Page 3 for the flow directional forms.

Products are adequately identified with nameplates indicating Form 1 as Form B or Form 2 as Form C. (mm)

Dimensions

Valve Size (inch)	d	d ₁	H	H ₁	L	L ₁	L ₂	S ₁	Actuator			
									H ₂	H ₃	D	Type
1/4	4.5	Rc1/4	101.5	25.5	46	23	23	21	70	5	60	EA100/200-1
3/8	6.8	Rc3/8	101.5	25.5	46	22	22	21				
1/2	10	Rc1/2	109.5	33.5	67	33.5	33.5	28				
3/4	15	Rc3/4	114	38	68	34	34	34				
1	20	Rc1	118	42	79	39.5	39.5	41				

Fig. EA100/200-TNE

Actuator size: 2
Valve size: 1/4" to 2" (Standard bore)

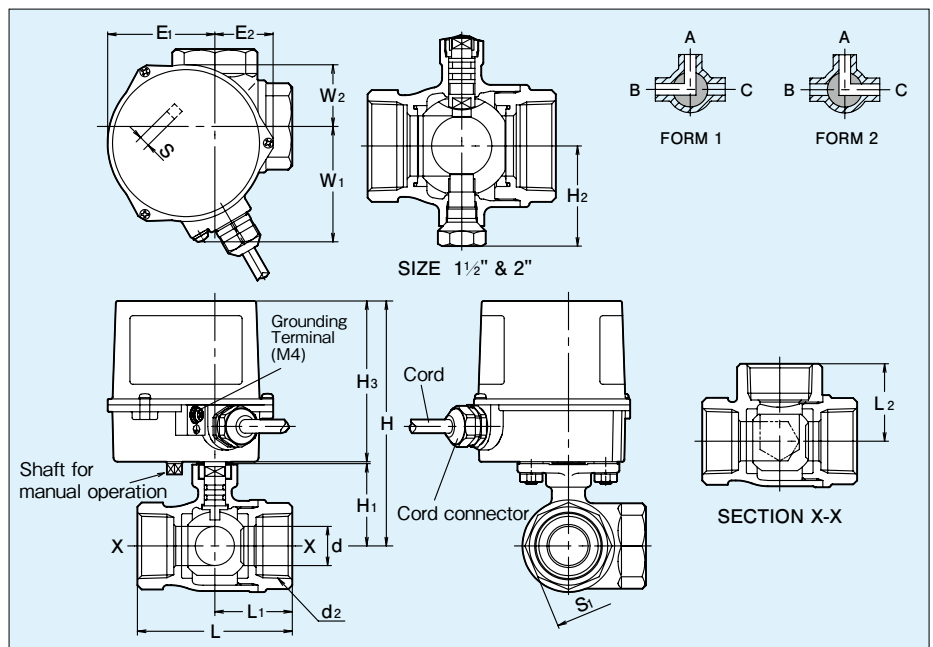

Note: Refer to Page 3 for the flow directional forms.

Products are adequately identified with nameplates indicating Form 1 as Form B or Form 2 as Form C. (mm)

Dimensions

Valve Size (inch)	d	d ₁	H	H ₁	H ₂	L	L ₁	L ₂	S ₁	Actuator						
										H ₃	E ₁	E ₂	W ₁	W ₂	S	Type
1/4	25	Rc1/4	128.5	46.5	—	89	44.5	44.5	50	82	54.5	30	59	31.5	5.5	EA100/200-2
1/2	32	Rc1/2	142.5	59.5	53.5	100	50	50	56							
2	40	Rc2	148.5	65.5	60	115	57.5	57.5	68							

Type EA Electric Actuators/Class 10K Union Nipple Bronze Ball Valves

Fig. EA100/200-TUE

Actuator size: 1
Valve size: 1/2" and 3/4" (Reduced bore)

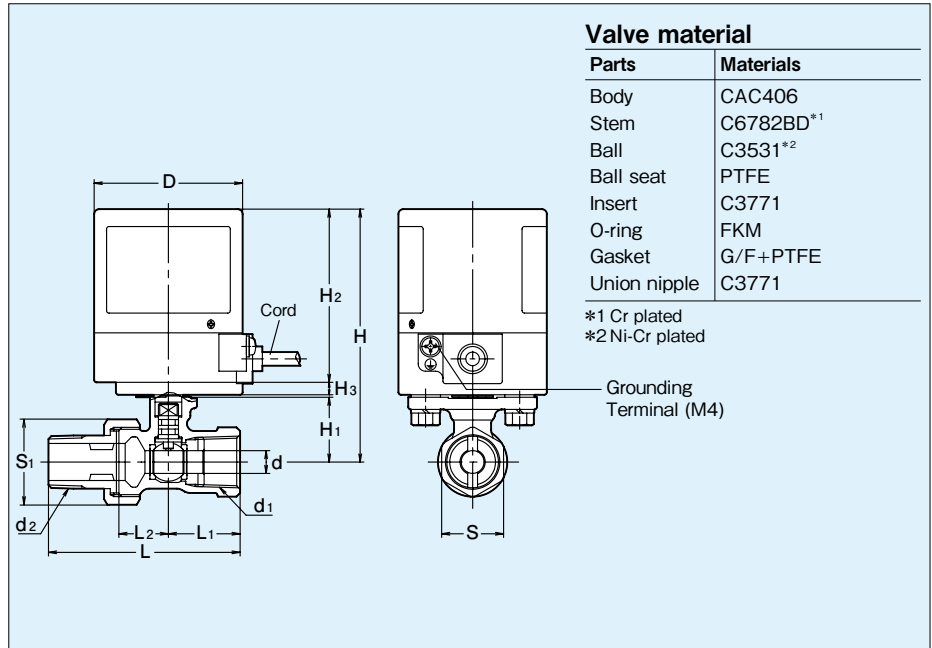

Dimensions

Valve Size (inch)	d	d ₁	d ₂	H	H ₁	L	L ₁	L ₂	S	S ₁	Actuator (mm)			
											H ₂	H ₃	D	Type
1/2	8	Rc1/2	Rc1/2	102	26	78.5	29	20	25	31	70	5	60	EA100/200-1
3/4	11	Rc3/4	Rc3/4	104.5	28.5	81	29	20	32	36				

Type EA Electric Actuators/Class 10K Long Neck Union Nipple Bronze Ball Valves

Fig. EA100/200-TLUE

Actuator size: 1
Valve size: 1/2" and 3/4" (Reduced bore)

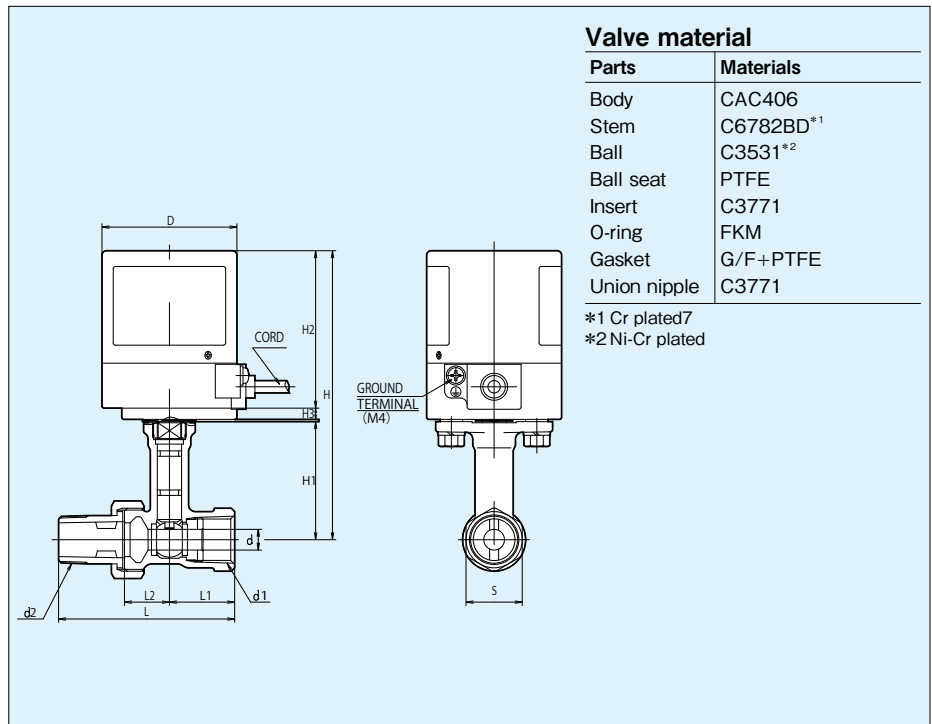

Dimensions

Valve Size (inch)	d	d ₁	d ₂	H	H ₁	L	L ₁	L ₂	S	S ₁	Actuator (mm)			
											H ₂	H ₃	D	Type
1/2	8	Rc1/2	Rc1/2	128.5	52.5	78.5	29	20	25	31	70	5	60	EA100/200-1
3/4	11	Rc3/4	Rc3/4	131	55	81	29	20	32	36				

Type EA Electric Actuators/Class 20K Long Neck Bronze Ball Valve

Fig. EA100/200-TLEK

Actuator size: 1 and 1.5
Valve size: 1/2" to 1" (Standard bore)

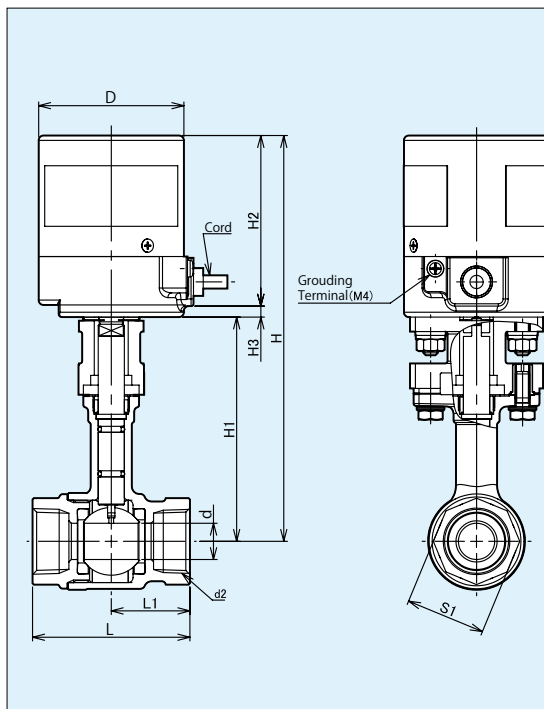

Valve material

Parts	Materials
Body	CAC406
Body Cap	CAC406
Stem	SUS304
Ball	SUS304*
Ball seat	PTFE
O-ring	FKM

* 1/2" & 2" : SUS316

Dimensions

Valve Size (inch)	d	d ₁	H	H ₁	L	L ₁	S ₁	Actuator			
								H ₂	H ₃	D	Type
1/2	10	Rc 1/2	163	88	56	28	27	70	5	60	EA100/200-1
3/4	15	Rc 3/4	168	93	65	32.5	33				EA100/200-1.5
1	20	Rc1	171	96	78	39	41				EA100/200-1.5

(mm)

Fig. EA100/200-TLEK

Actuator size: 2
Valve size: 1 1/4" to 2" (Standard bore)

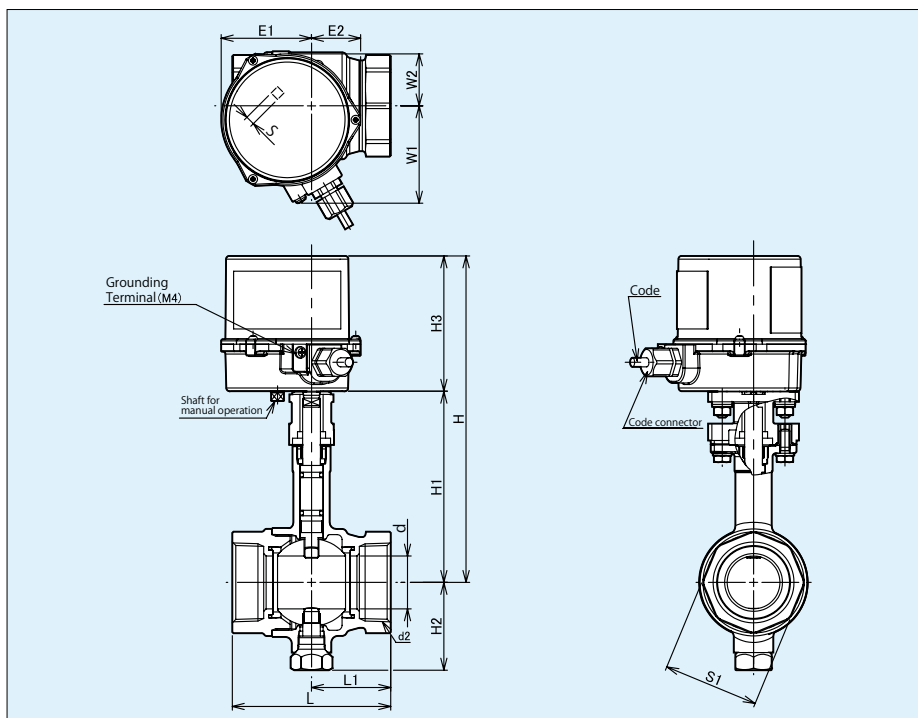

Dimensions

Valve Size (inch)	d	d ₁	H	H ₁	H ₂	L	L ₁	S ₁	Actuator						
									H ₃	E ₁	E ₂	W ₁	W ₂	S	Type
1 1/4	25	Rc1 1/4	195	113	—	86	43	51	82	54.5	30	59	31.5	5.5	EA100/200-2
1 1/2	32	Rc1 1/2	198	116	53	96	48	58							
2	40	Rc2	204	204	60	109	54.5	71							

(mm)

Type EA Electric Actuators/Class 10K Stainless Steel Ball Valves

Fig. EA100/200-UTE

Actuator size: 1 and 1.5
Valve size: 1/4" to 1" (Reduced bore)



*RoHS

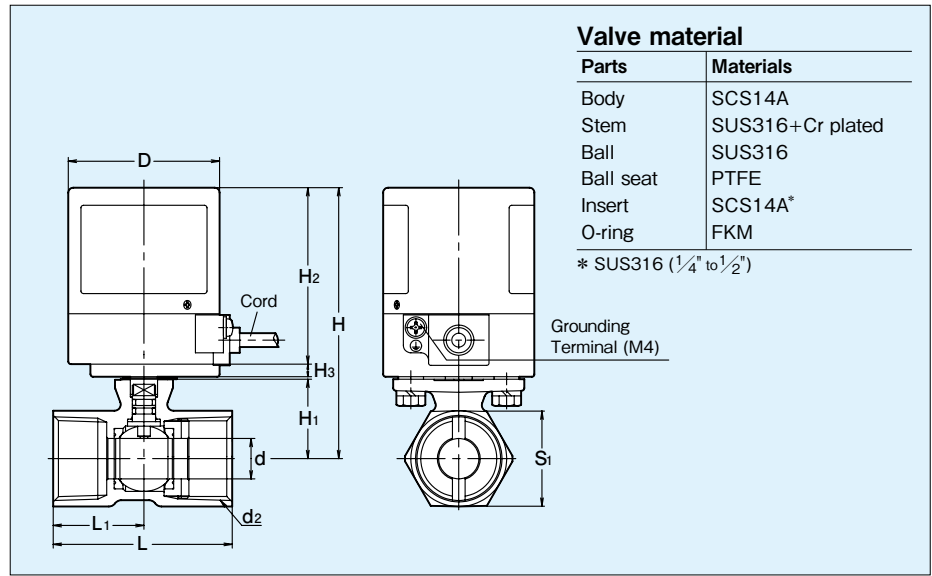

Valve material

Parts	Materials
Body	SCS14A
Stem	SUS316+Cr plated
Ball	SUS316
Ball seat	PTFE
Insert	SCS14A*
O-ring	FKM

* SUS316 (1/4" to 1/2")

Grounding Terminal (M4)

Dimensions

(mm)

Valve Size (inch)	d	d ₁	H	H ₁	L	L ₁	S ₁	Actuator			
								H ₂	H ₃	D	Type
1/4	4.5	Rc1/4	102	26	44	21	21	70	5	60	EA100/200-1
3/8	6.8	Rc3/8	102	26	44	21	21				
1/2	9.2	Rc1/2	102	26	56.5	27.5	25				
3/4	12.5	Rc3/4	105	29	59	30	32				
1	16	Rc1	108	32	71	36	38				EA100/200-1.5

Fig. EA100/200-UTE

Actuator size: 2
Valve size: 1 1/4" to 2" (Reduced bore)

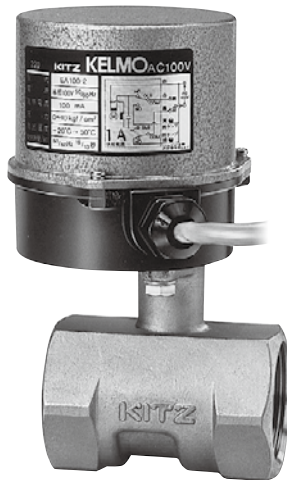

*RoHS

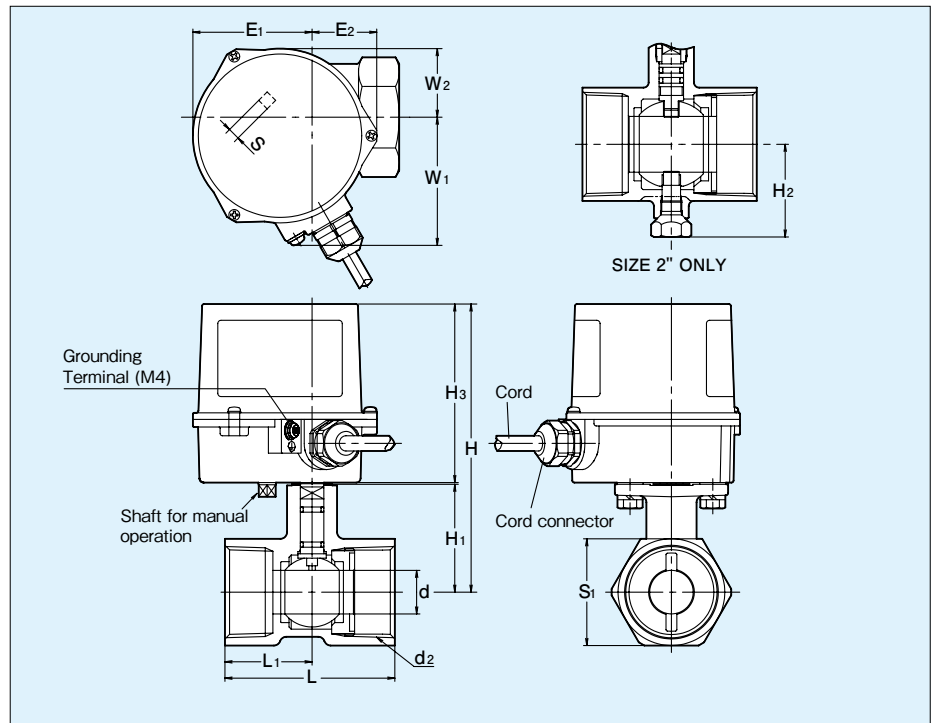

Dimensions

(mm)

Valve Size (inch)	d	d ₁	H	H ₁	H ₂	L	L ₁	S ₁	Actuator						
									H ₃	E ₁	E ₂	W ₁	W ₂	S	Type
1 1/4	20	Rc1 1/4	132.5	49.5	—	78	40	49	82	54.5	30	59	31.5	5.5	EA100/200-2
1 1/2	24.5	Rc1 1/2	135.5	52.5	—	83	42.5	53							
2	32	Rc2	141.5	58.5	53.5	100	51	65							

Type EA Electric Actuators/Class 10K Stainless Steel Ball Valves

Fig. EA100/200-UTFE

Actuator size: 1.5
Valve size: 1/2" and 3/4" (Full bore)



*RoHS

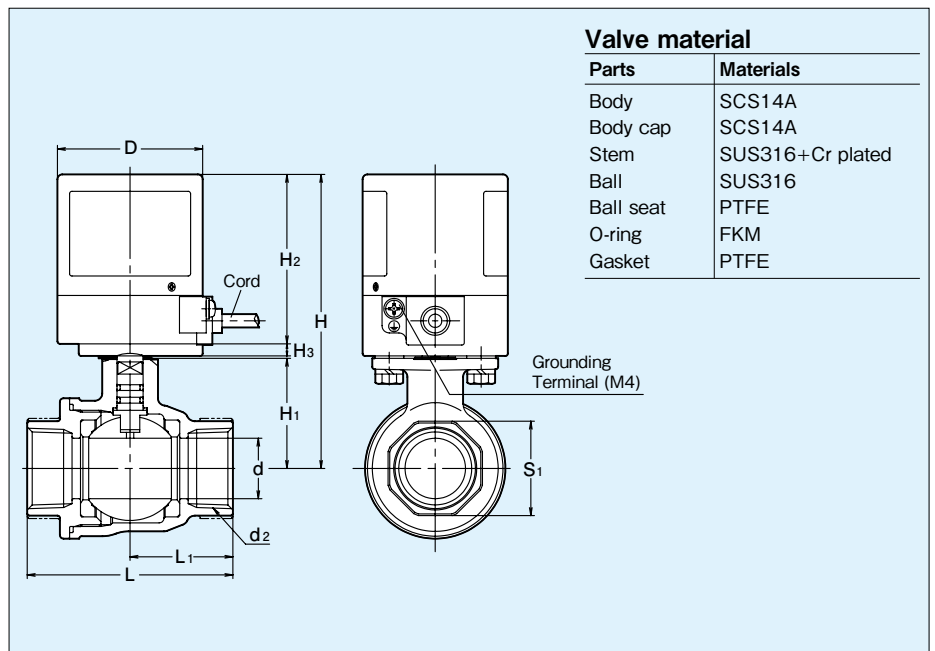

Dimensions

Valve Size (inch)	d	d ₁	H	H ₁	L	L ₁	S ₁	Actuator			
								H ₂	H ₃	D	Type
1/2	15	Rc1/2	113.5	37.5	63	31	26	70	5	60	EA100/200-1.5
3/4	20	Rc3/4	117.5	41.5	73	36.5	32				

(mm)

Fig. EA100/200-UTFE

Actuator size: 2
Valve size: 1" to 1 1/2" (Full bore)

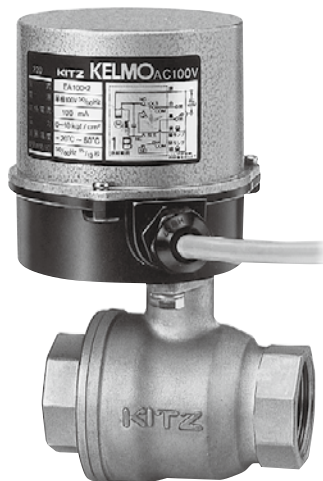

*RoHS

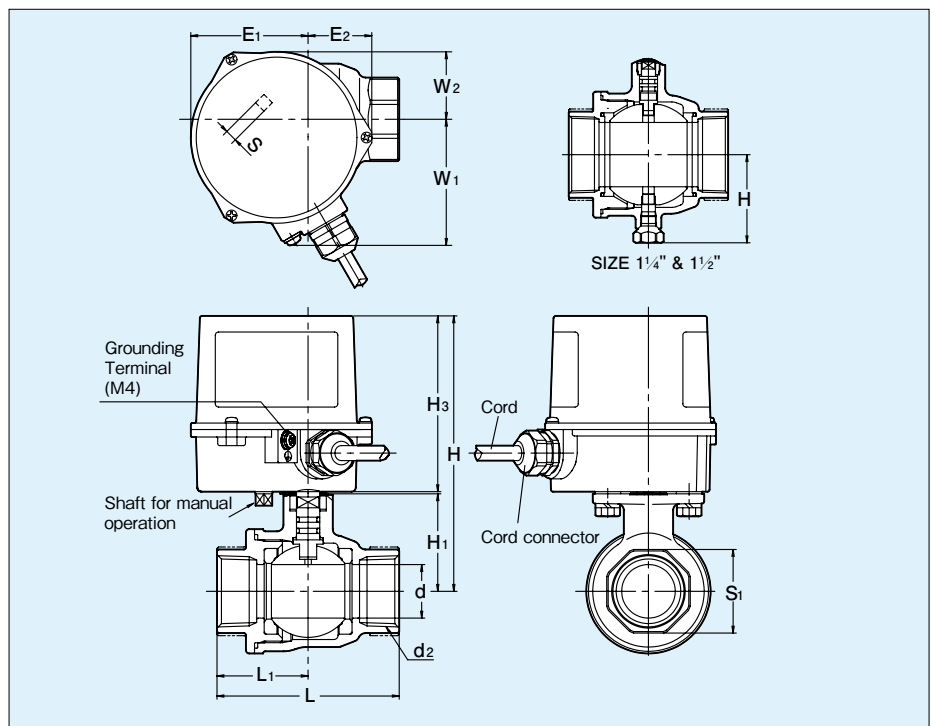

Dimensions

Valve Size (inch)	d	d ₁	H	H ₁	H ₂	L	L ₁	S ₁	Actuator						
									H ₃	E ₁	E ₂	W ₁	W ₂	S	Type
1	25	Rc1	128.5	45.5	—	85	42.5	39	82	54.5	30	59	31.5	5.5	EA100/200-2
1 1/4	32	Rc1 1/4	143.5	60.5	55	98	49	48							
1 1/2	40	Rc1 1/2	149.5	66.5	61	108	54	54							

(mm)

Type EA Electric Actuators/Class 10K Glanded Stainless Steel Ball Valves

Fig. **EA100/200-UTGE**

Actuator size: 2
 Valve size: 1/4" to 1" (Reduced bore)

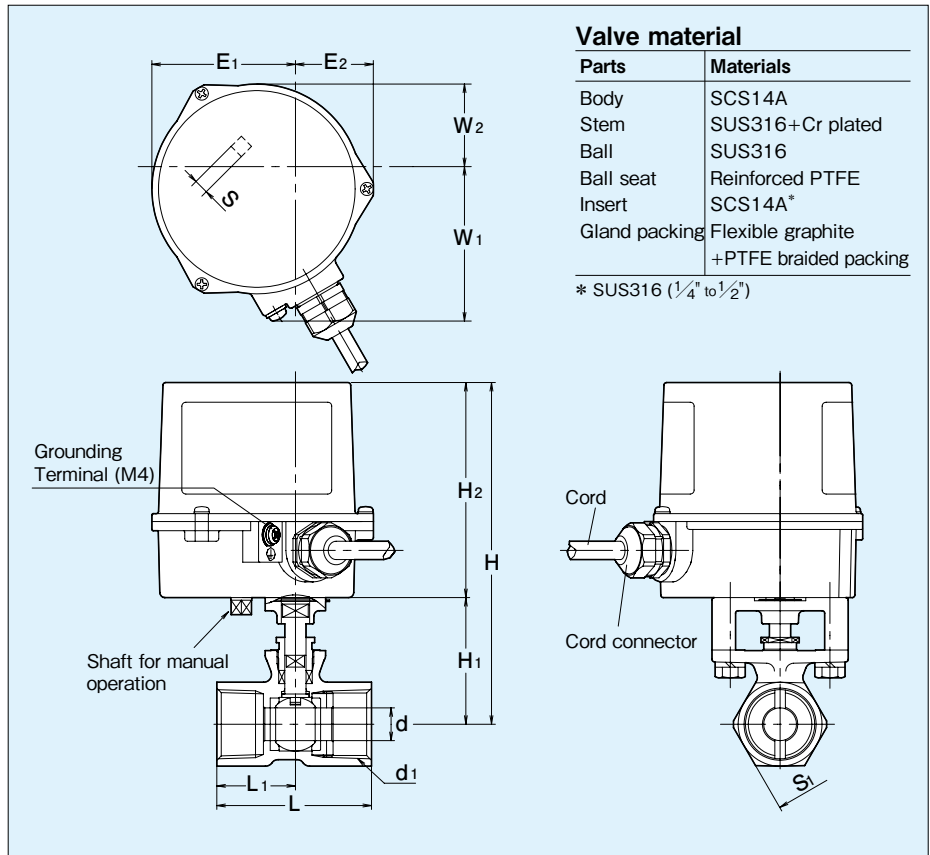

*RoHS

Dimensions

(mm)

Valve Size (inch)	d	d ₁	H	H ₁	L	L ₁	S ₁	Actuator						
								H ₂	E ₁	E ₂	W ₁	W ₂	S	Type
1/4	4.5	Rc1/4	128	46	44	21	21	82	54.5	30	59	31.5	5.5	EA100/200-2
3/8	6.8	Rc3/8	128	46	44	21	21							
1/2	9.2	Rc1/2	128	46	56.5	27.5	25							
3/4	12.5	Rc3/4	131	49	59	30	32							
1	16	Rc1	134	52	71	36	38							

Type EA Electric Actuators/Class 10K Horizontal 3-way Stainless Steel Ball Valve

Fig. EA100/200-UTNE

Actuator size: 1 and 1.5
Valve size: 1/2" to 1" (Reduced bore)



*RoHS

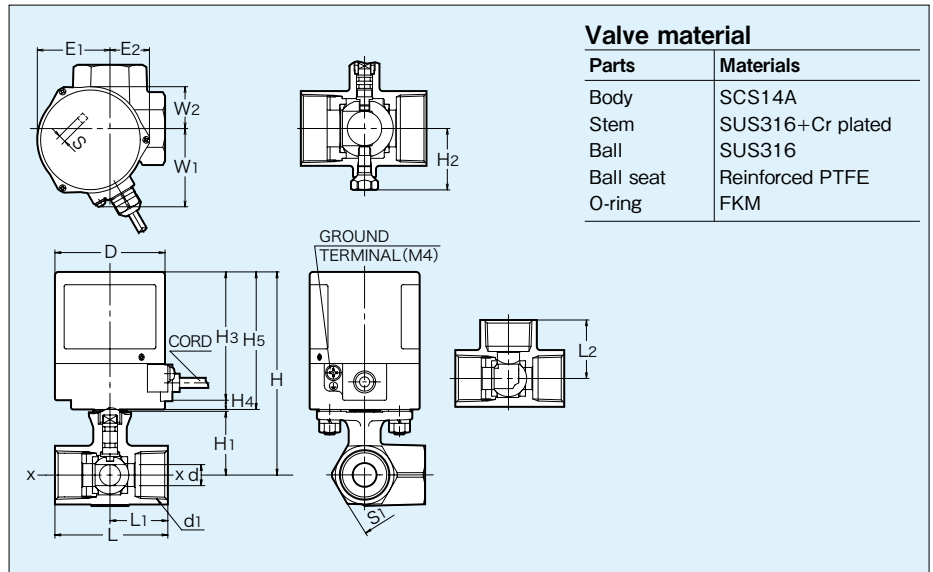

Note: Refer to Page2 for the flow directional forms.
Products are adequately identified with nameplates indicating Form 1 as Form B or Form 2 as Form C.

Dimensions

(mm)

Valve Size (inch)	d	d ₁	H	H ₁	L	L ₁	L ₂	S ₁	Actuator			
									H ₂	H ₃	D	Type
1/4	4.5	Rc 1/4	101.5	25.5	44	21	23	21	70	5	60	EA100/200-1
3/8	6.8	Rc 3/8	101.5	25.5	44	21	23	21				
1/2	8.5	Rc 1/2	106.5	30.5	58	29	29	25				
3/4	11.5	Rc 3/4	110.5	34.5	61.5	31.5	33	32				
1	15	Rc1	114	38	74	37.5	39.5	38				

Fig. EA100/200-UTNE

Actuator size: 2
Valve size: 1 1/4" to 2" (Reduced bore)



*RoHS

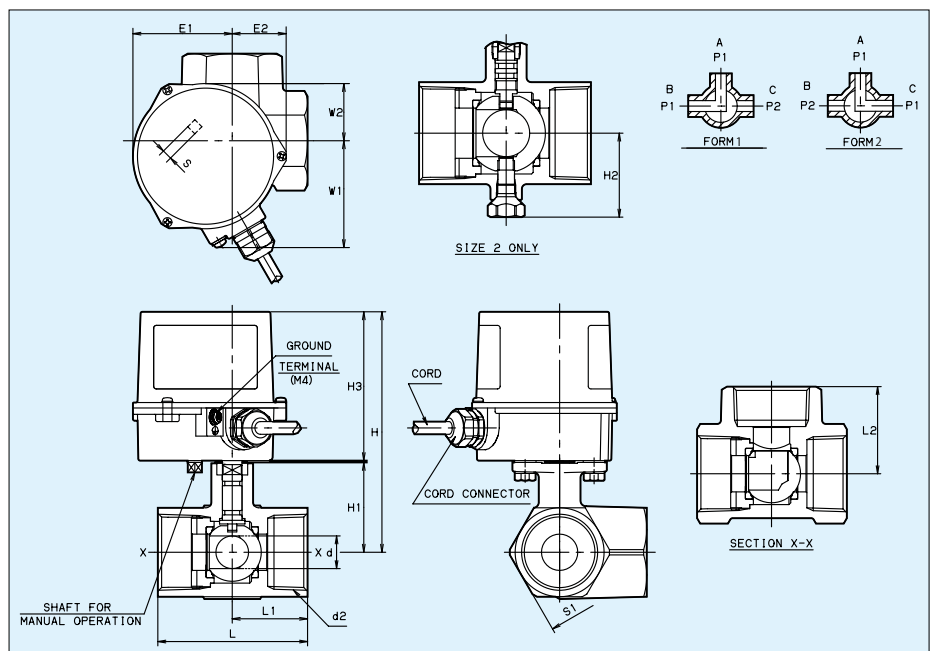

Note: Refer to Page2 for the flow directional forms.
Products are adequately identified with nameplates indicating Form 1 as Form B or Form 2 as Form C.

Dimensions

(mm)

Valve Size (inch)	d	d ₁	H	H ₁	H ₂	L	L ₁	L ₂	S ₁	Actuator						Type
										H ₃	E ₁	E ₂	W ₁	W ₂	S	
1 1/4	18	Rc1 1/4	132.5	49.5	—	82.5	41.5	48	49	82	54.5	30	59	31.5	5.5	EA100/200-2
1 1/2	23	Rc1 1/2	135.5	52.5	—	90.5	44.5	54	53							
2	30	Rc2	141.5	58.5	53.5	109.5	54	65	65							

Type EA Electric Actuators/Class 5K/10K Wafer Stainless Steel Ball Valves

Fig. **EA100/200-5UTWE**
EA100/200-10UTWE

Actuator size: 1 and 1.5
Valve size: 3/8" to 3/4" (Full bore)



* RoHS

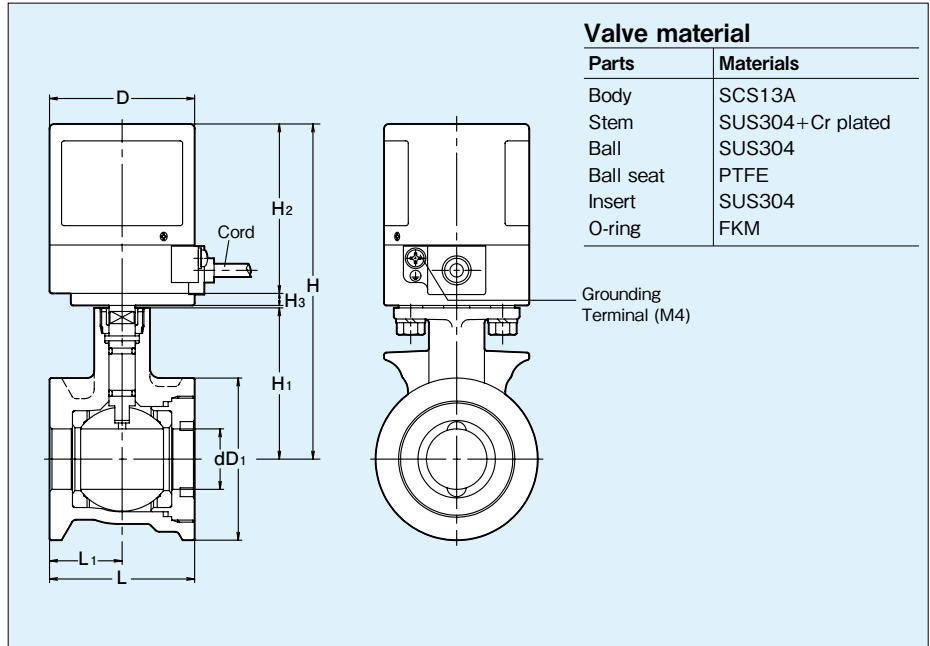

Valve material

Parts	Materials
Body	SCS13A
Stem	SUS304+Cr plated
Ball	SUS304
Ball seat	PTFE
Insert	SUS304
O-ring	FKM

Dimensions

Valve Size (inch)	d	H	H ₁	L	L ₁	D ₁		Actuator			Type
						5K	10K	H ₂	H ₃	D	
3/8	10	131	55	35	17.5	43	48	70	5	60	EA100/200-1
1/2	15	134	58	40	20	48	53				EA100/200-1.5
3/4	20	136	60	50	25	53	58				

(mm)

Fig. **EA100/200-5UTWE**
EA100/200-10UTWE

Actuator size: 2
Valve size: 1" (Full bore)

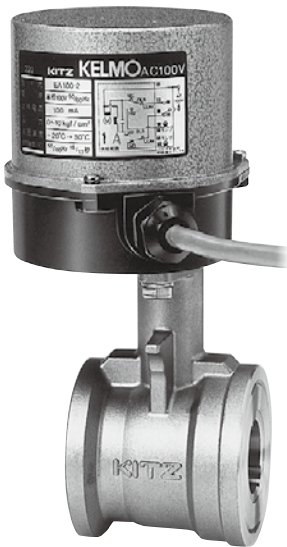

* RoHS

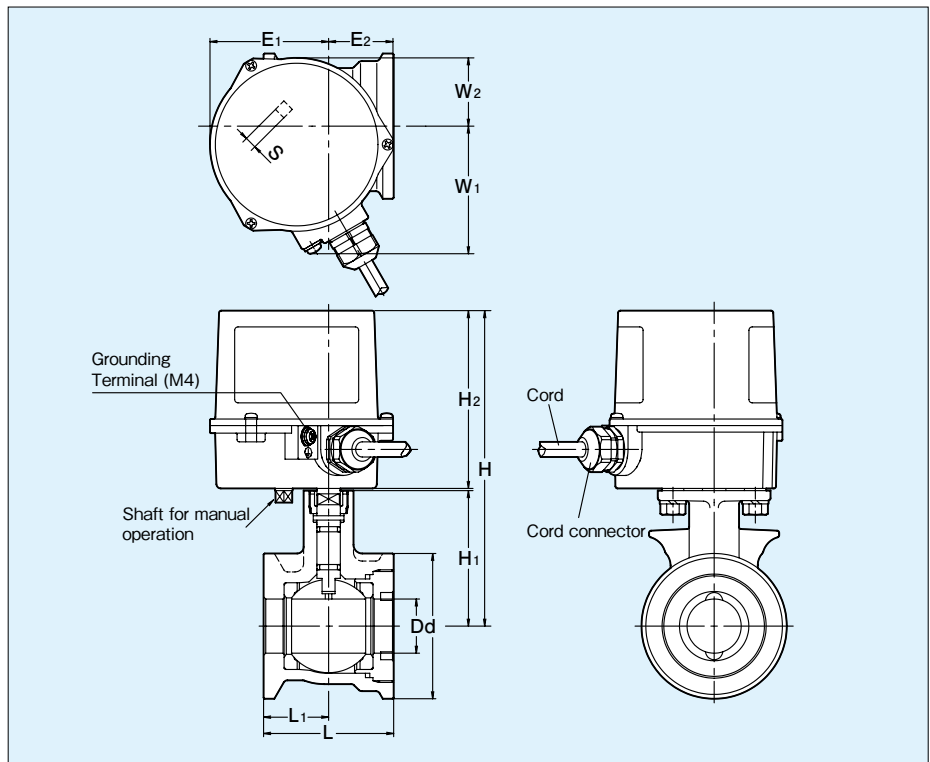

Dimensions

Valve Size (inch)	d	H	H ₁	L	L ₁	D		Actuator					Type	
						5K	10K	H ₂	E ₁	E ₂	W ₁	W ₂		S
1	25	151	68	60	30	63	69	82	54.5	30	59	31.5	5.5	EA100/200-2

(mm)

Type EAB Electric Actuators/Class 10K Bronze or Stainless Steel Ball Valves

The circuit diagram is the same as the one for Type EA actuators.

Refer to Page 5.

Note: Terminal box (M3) is equipped for electric connection with the power source.

Fig. of actuator-to-valve assemblies *RoHS

- | | |
|------------------------|-------------------------------|
| EAB100/200-TE | EAB100/200-UTE* |
| EAB100/200-TFE | EAB100/200-UTFE* |
| EAB100/200-TLE | EAB100/200-UTGE* |
| EAB100/200-TNE | EAB100/200-UTNE* |
| EAB100/200-TGE | EAB100/200-5 / 10UTWE* |
| EAB100/200-TUE | |
| EAB100/200-TLUE | |
| EAB100/200-TLEK | |

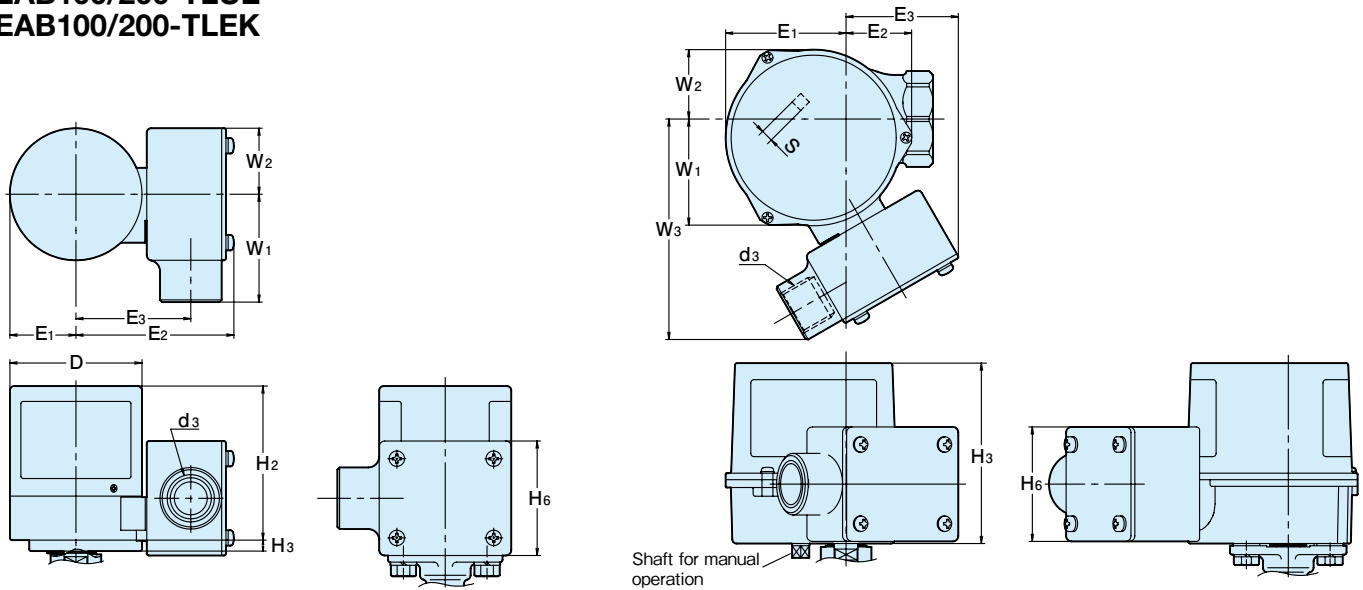

Dimensions of actuator size 1 & 1.5 (mm)

d ₃	H ₂	H ₃	H ₆	E ₁	E ₂	E ₃	W ₁	W ₂	D
G ¹ / ₂	70	5	52	30	72	52	49	30	60

Note: Actuator sizing for ball valves is the same as the one for Type EA actuators.

Dimensions of actuator size 2 (mm)

d ₃	H ₃	H ₆	E ₁	E ₂	E ₃	W ₁	W ₂	W ₃	S
G ¹ / ₂	82	52	54.5	30	52	49	31.5	100	5.5

Note: Actuator sizing for ball valves is the same as the one for Type EA actuators.

Type EAL and EALB Electric Actuators/Class 10K Bronze or Stainless Steel Ball Valves

100/200V AC 50/60Hz

- **Built-in relay circuit for parallel drive of two or more actuators**
- **Factory-assembled terminal box for easier installation of actuators (EALB)**

Type EAL and EALB actuator design specifications

Specification \ Type	EAL100-1 EALB100-1	EAL200-1 EALB200-1	EAL100-1.5 EALB100-1.5	EAL200-1.5 EALB200-1.5	EAL100-2 EALB100-2	EAL200-2 EALB200-2
Power source 50/60Hz	100V AC	200V AC	100V AC	200V AC	100V AC	200V AC
Rated current	100mA	60mA	100mA	60mA	110mA	60mA
Max. power consumption	10W	12W	10W	12W	11W	12W
Valve closing time 90°	50Hz	Approx. 6 s		Approx. 12 s		Approx. 15 s
	60Hz	Approx. 5 s		Approx. 10 s		Approx. 13 s
Max. output torque	1.9N·m		3.9N·m		9.8N·m	
Rated time	Continuous					
Insulation Class	JIS Class E					
Sensitive switch contact capacity	125V AC 2A, 250V AC 0.6A (Resistance load)				250V AC 2A (Resistance load)	
Position limit switch	One unit each for opening/closing (Voltage output)					
Insulation strength	1500V AC (1 min. interval)					
Insulation resistance	Minimum 10MΩ (500V DC)					
Standard protection	All weather type (for outdoor use, avoid exposure to direct sunlight)					
Ambient temperature	-20°C to +50°C					
Mounting position	Vertical to horizontal					
Wiring	Vinyl cabtyre cord with five cores, 700mm in length					
	0.3mm ²			0.5mm ²		
Lubrication	Grease					
Overload protection	Impedance protection					
Coating color	Housing: black Cover: light blue					

* Terminals (M3) are used to connect EALB with the power source.

Fig. of actuator-to-valve assemblies

- EAL100/200-TE EAL100/200-UTE**
- EAL100/200-TFE EAL100/200-UTFE**
- EAL100/200-TLE EAL100/200-UTGE**
- EAL100/200-TNE EAL100/200-5/10UTWE**
- EAL100/200-TUE EAL100/200-UTNE**
- EAL100/200-TGE**
- EAL100/200-TLUE**
- EAL100/200-TLEK**

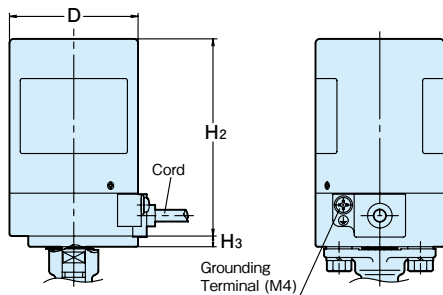

Dimensions of actuator size 1 & 1.5 (mm)

H ₂	H ₃	D
92	5	60

Note: Refer to Page 17 for actuator sizing for ball valves.

Type EAL actuator circuit diagrams

(with the valve fully closed)

EAL100/200 Size 1, 2

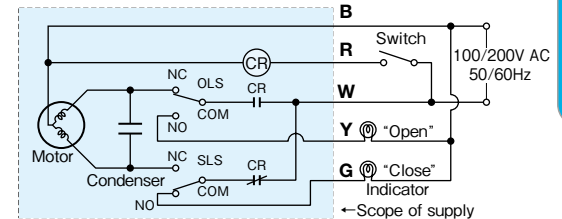

- Wire color: **B** black **R** red **W** white **Y** yellow **G** green
 - Actuator rotates:
Switch ON: Counter-clockwise to fully open the valve
Switch OFF: Clockwise to fully close the valve
 - Limit switches activate:
OLS: on fully opening the valve (B-W: off W-Y: on)
SLS: on fully closing the valve (B-W: off W-G: on)
- Note: For all sizes of Type EALB100/200, the terminals are numbered 1, 2, 3, 4 and 5 in place of B, R, W, Y and G respectively.

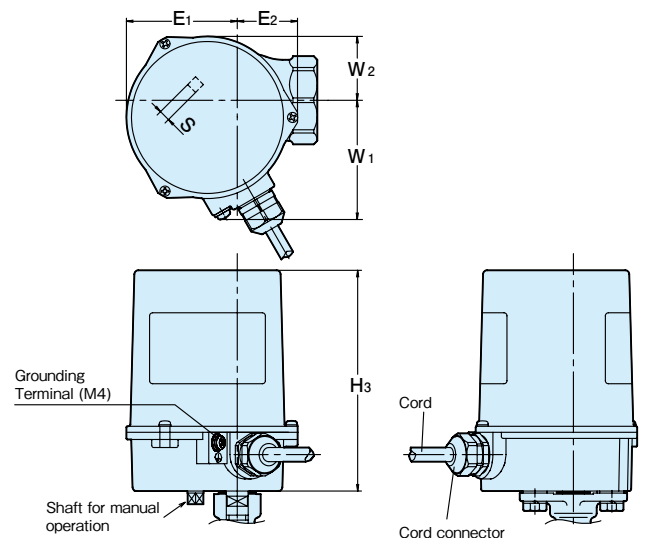

Dimensions of actuator size 2 (mm)

H ₃	E ₁	E ₂	W ₁	W ₂	S
108.5	54.5	30	59	31.5	5.5

Type EALB Electric Actuators/Class 10K Bronze or Stainless Steel Ball Valves

The circuit diagram is the same as the one for Type EAL actuators.

Refer to Page 22

Note: Terminal box (M3) is equipped for electric connection with the power source.

Fig. of actuator-to-valve assemblies

- | | | |
|--|---|---|
| <p>EALB100/200-TE
 EALB100/200-TFE
 EALB100/200-TLE
 EALB100/200-TNE
 EALB100/200-TUE</p> | <p>EALB100/200-TGE
 EALB100/200-TLUE
 EALB100/200-TLEK</p> | <p>EALB100/200-UTE
 EALB100/200-UTFE
 EALB100/200-UTGE
 EALB100/200-5/10UTWE
 EALB100/200-UTNE</p> |
|--|---|---|

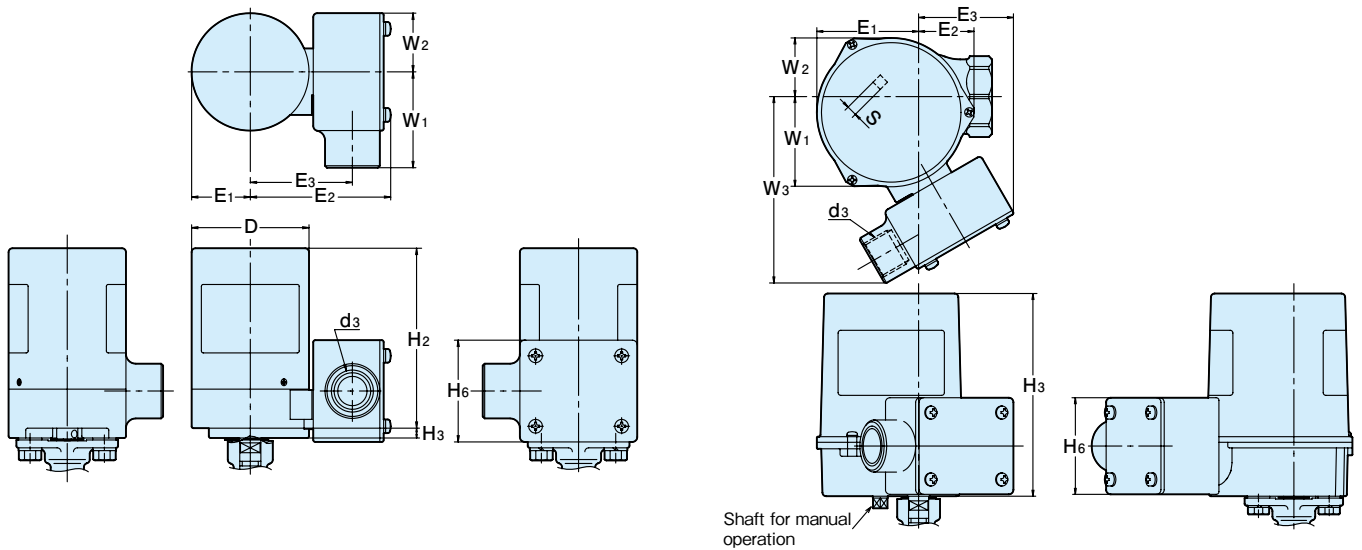

Dimensions of actuator size 1 & 1.5 (mm)

d ₃	H ₂	H ₃	H ₆	E ₁	E ₂	E ₃	W ₁	W ₂	D
G ¹ / ₂	92	5	52	30	72	52	49	30	60

Dimensions of actuator size 2 (mm)

d ₃	H ₃	H ₆	E ₁	E ₂	E ₃	W ₁	W ₂	W ₃	S
G ¹ / ₂	108.5	52	54.5	30	52	49	31.5	100	5.5

Actuator sizing table (EA, EAB, EAL, EALB Type)

Fig	Size	1/4	3/8	1/2	3/4	1	1 1/4	1 1/2	2
TE		Type 1			Type 1.5		Type 2		
TFE		Type 1.5			Type 2				
TLE		Type 1		Type 1.5		Type 2			
TLEK		Type 1		Type 1.5		Type 2			
TUE		Type 1							
TLUE		Type 1							
TNE		Type 1			Type 1.5		Type 1.5		
UTE		Type 1				Type 1.5		Type 2	
UTFE		Type 1.5			Type 2				
UTGE		Type 2							
UTNE		Type 1				Type 1.5		Type 2	
5/10UTWE		Type 1		Type 1.5		Type 2			
UTKLAHE		Type 2							
UTEX		Type 1				Type 1.5		Type 2	

Type EAH and EAHB Electric Actuators/Class 10K Vertical 3-way Bronze or Stainless Steel Ball Valves

100/200V AC 50/60Hz

- Automated change of flow direction
- Choice of three-way operation: two different flow passages and flow block without leakage
- Exclusive mounting with KITZ TNVE & UTVE ball valves
- Factory-assembled terminal box for easier installation of actuators (EAHB)

Type EAH and EAHB actuator design specifications

Specification \ Type	EAH100-1 EAHB100-1	EAH200-1 EAHB200-1	EAH100-1.5 EAHB100-1.5	EAH200-1.5 EAHB200-1.5	EAH100-2 EAHB100-2	EAH200-2 EAHB200-2
Power source 50/60Hz	100V AC	200V AC	100V AC	200V AC	100V AC	200V AC
Rated current	90mA	50mA	90mA	50mA	100mA	50mA
Max. power consumption	9W	10W	9W	10W	10W	
Valve closing time 90°	50Hz	Approx. 12 s		Approx. 24 s		Approx. 30 s
	60Hz	Approx. 10 s		Approx. 20 s		Approx. 26 s
Max. output torque	1.9N·m		3.9N·m		9.8N·m	
Rated time	Continuous					
Insulation class	JIS Class E					
Sensitive switch contact capacity	125V AC 2A, 250V AC 0.6A (Resistance load)				250V AC 2A (Resistance load)	
Position limit switch	One unit each for opening/closing (Voltage output)					
Insulation strength	1500V AC (1 min. interval)					
Insulation resistance	Minimum 10MΩ (500V DC)					
Standard protection	All weather type (for outdoor use, avoid exposure to direct sunlight)					
Ambient temperature	-20°C to +50°C					
Mounting position	Vertical to horizontal					
Wiring	Vinyl cabtyre cord with five cores, 700mm in length					
	0.3mm ²				0.5mm ²	
Lubrication	Grease					
Overload protection	Impedance protection					
Coating color	Housing: black Cover: light blue					

* Terminals (M3) are used to connect EAHB with the power source.

Type EAH actuator circuit diagrams

(with the valve positioned at Form 2)

EAH100/200

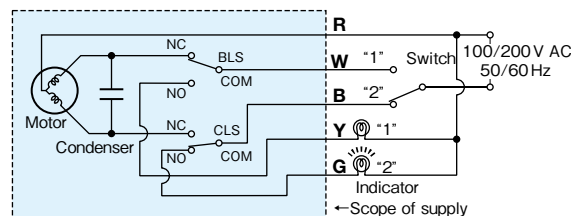

- Wire color: **R** red **W** white **B** black **Y** yellow **G** green
- Actuator rotates: **R-W**: clockwise to Form 1
R-B: counter-clockwise to Form 2
- Limit switches activate: BLS: at Form 1 (R-W: off W-Y: on)
CLS: at Form 2 (R-B: off B-G: on)

Note: For all sizes of Type EAHB100/200, the terminals are numbered 1, 2, 3, 4 and 5 in place of R, W, B, Y and G respectively.

Type EAH Electric Actuators/Class 10K Vertical 3-way Bronze Steel Ball Valves

Fig. EAH100/200-TNVE

Actuator size: 1 & 1.5
Valve size: 1/2" to 1" (Standard bore)

Valve material

Parts	Materials
Body	CAC406
Body cap	C3771
Stem	C6782*1
Ball	C3531*2
Ball seat	PTFE
O-ring	FKM

*1 Cr plated
*2 Ni-Cr plated

Fig. EAH100/200-TNVE

Actuator size: 2
Valve size: 1 1/4" (Standard bore)

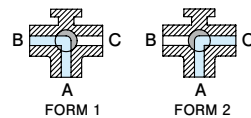
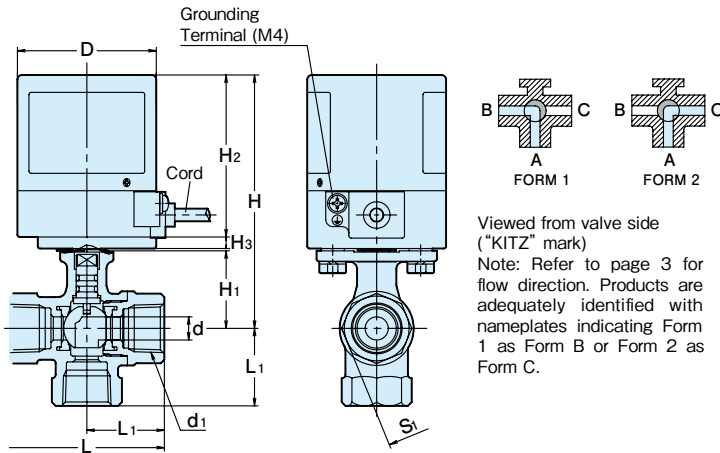

Viewed from valve side ("KITZ" mark)
Note: Refer to page 3 for flow direction. Products are adequately identified with nameplates indicating Form 1 as Form B or Form 2 as Form C.

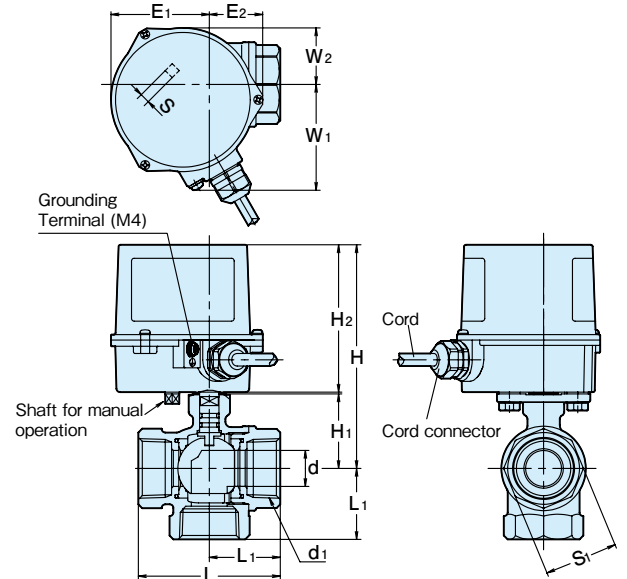

Dimensions of actuator size 1 & 1.5 (mm)

Valve Size (inch)	d	d ₁	H	H ₁	L	L ₁	Actuator			
							H ₂	H ₃	D	Type
1/2	10	Rc1/2	109.5	33.5	67	33.5	70	5	60	EAH100/200-1
3/4	15	Rc3/4	113.5	37.5	68	34.0				EAH100/200-1.5
1	20	Rc1/2	117.5	41.5	79	39.5				

Dimensions of actuator size 2 (mm)

Valve Size (inch)	d	d ₁	H	H ₁	L	L ₁	S ₁	Actuator						
								H ₂	E ₁	E ₂	W ₁	W ₂	S	Type
1 1/4	25	Rc1/4	129.5	46.5	89	44.5	50	82	54.5	30	59	31.5	5.5	EAH100/200-2

Note: Contact KITZ for technical advice when valve operation at an intermediate position is required

Type EAH Electric Actuators/Class 10K Vertical 3-way Stainless Steel Ball Valves

Fig. EAH100/200-UTVE

Actuator size: 1 & 1.5
Valve size: 1/4" to 1" (Reduced bore)

Valve material

Parts	Materials
Body	SCS14A
Stem	SUS316+Cr plated
Ball	SUS316
Ball seat	PTFE
Insert	SUS316
O-ring	FKM

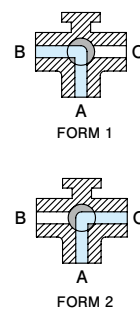
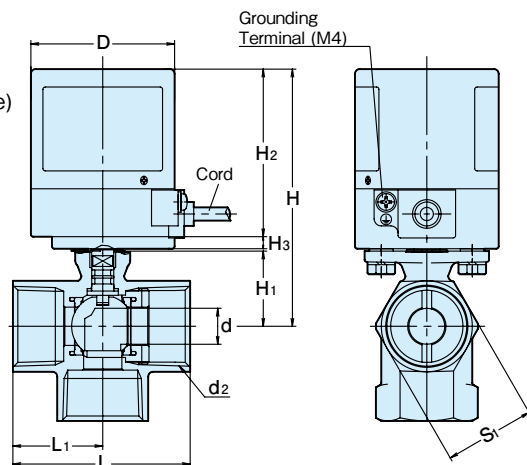

Viewed from valve side ("KITZ" mark)
Note: Refer to page 3 for flow direction. Products are adequately identified with nameplates indicating Form 1 as Form B or Form 2 as Form C.

Dimensions

Valve Size (inch)	d	d ₁	H	H ₁	L	L ₁	S ₁	Actuator			
								H ₂	H ₃	D	Type
1/4	4.5	Rc1/4	101.5	25.5	44.0	21.0	21	70	5	60	EAH100/200-1
3/8	6.8	Rc3/8	101.5	25.5	44.0	21.0	21				
1/2	8.5	Rc1/2	102.0	26.0	58.0	29.0	25				
3/4	11.5	Rc3/4	104.5	28.5	61.5	31.5	32				
1	15.0	Rc1	107.5	31.5	74.0	37.5	38				

Note: Contact KITZ for technical advice when valve operation at an intermediate position is required

Type EAHB Electric Actuators/Class 10K Vertical 3-way Bronze or Stainless Steel Ball Valves with Terminal Box

The circuit diagram is the same as the one for Type EAL actuators.

Refer to Page 18.

Note: Terminal box (M3) is equipped for electric connection with the power source.

Fig. of actuator-to-valve assemblies

**EAHB100/200-TNVE
EAHB100/200-UTVE**

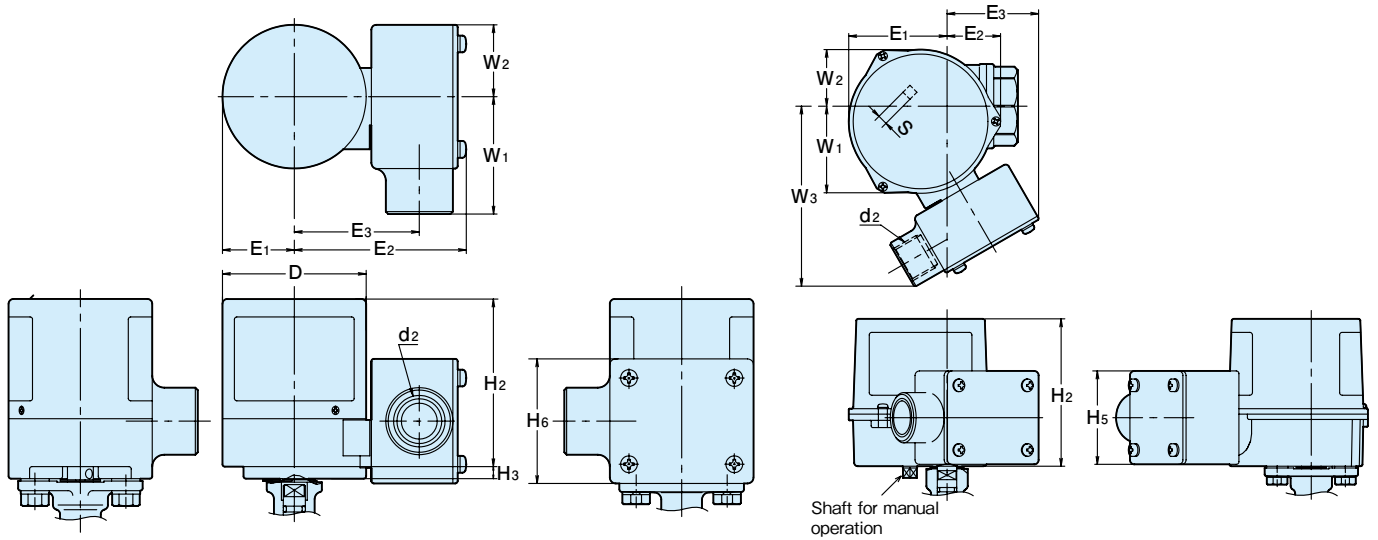

Types EAH · EAHB

Dimensions of actuator size 1 & 1.5 (mm)

d ₂	H ₂	H ₃	H ₆	E ₁	E ₂	E ₃	W ₁	W ₂	D
G ¹ / ₂	70	5	52	30	72	52	49	30	60

Dimensions of actuator size 2 (mm)

d ₂	H ₂	H ₅	E ₁	E ₂	E ₃	W ₁	W ₂	W ₃	S
G ¹ / ₂	82	52	54.5	30	52	49	31.5	100	5.5

KELMO® EAE Series Spring Electric Actuator

100/200V AC 50/60Hz

- **Two-wire power supply system for easy replacement of conventional solenoid valves as a valve actuating device.**
- **Modest operating speed with no concern of water hammer, which is a problem for conventional solenoid valves.**
- **Availability of manual operation.**
- **Auto-lock provision to hold valve opening position when the actuator is turned off.**

Type EAE actuator design specifications

Specification	Type	EAE100-1	EAE200-1
Power source	50/60Hz	100V AC	200V AC
Rated current		200mA	100mA
Max. power consumption		8.5W	7.2W
Valve closing time 90°	50/60Hz	Approx. 10 sec.	
	Spring return	Approx. 20 sec.	
Rated time		Continuous	
Insulation Class		JIS Class E	
Insulation strength		1500V AC (1 min. interval)	
Insulation resistance		Minimum 100MΩ (500V DC)	
Standard protection		for indoor use*	
Ambient temperature		-10°C to +50°C	
Mounting position		Vertical to horizontal	
Wiring		0.3mm ² lead wire	
Lubrication		Grease	
Coating color		Housing: black Cover: light blue	

*The use in outdoor, such as the place where the actuator may get splashed or the place of high humidity, is prohibited.
Terminal boxes and cable glands are available as an option.

Actuator circuit diagrams

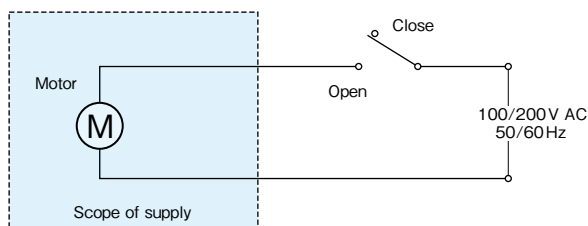

Operating mechanism

- The basic mechanical structure is given in the illustration below.
- Energizing an actuator rotates a motor and transfer the torque to a one-way clutch via reducing gears. The torque will be, then, transferred to the shaft and will open the valve, while winding up the core spring simultaneously.
- 90° rotation of the shaft activates an automatic lever to contact a stopper and stay in thus fixed position, while the actuator remains energized.
- De-energizing an actuator activates the ball to rotate clockwise to its closed position, by means of repulsing force of the coil spring.

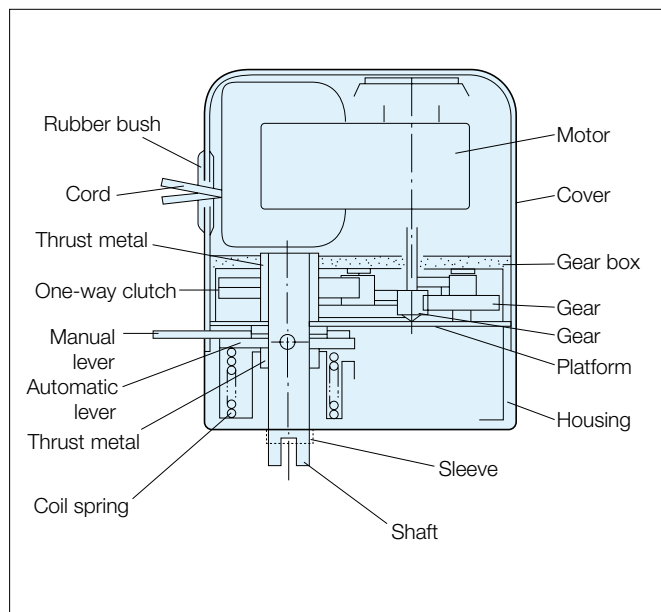

Type EAE Electric Actuators/Class 10K* Bronze, Brass or Stainless Steel Ball Valves

Fig. of actuator-to-valve assemblies
EAE100/200-TE (3/8" and 1/2")
EAE100/200-TNE* (1/4" to 1/2")
EAE100/200-TUE (1/2")
EAE100/200-UTE (1/4" to 1/2")
EAE100/200-TKSE*

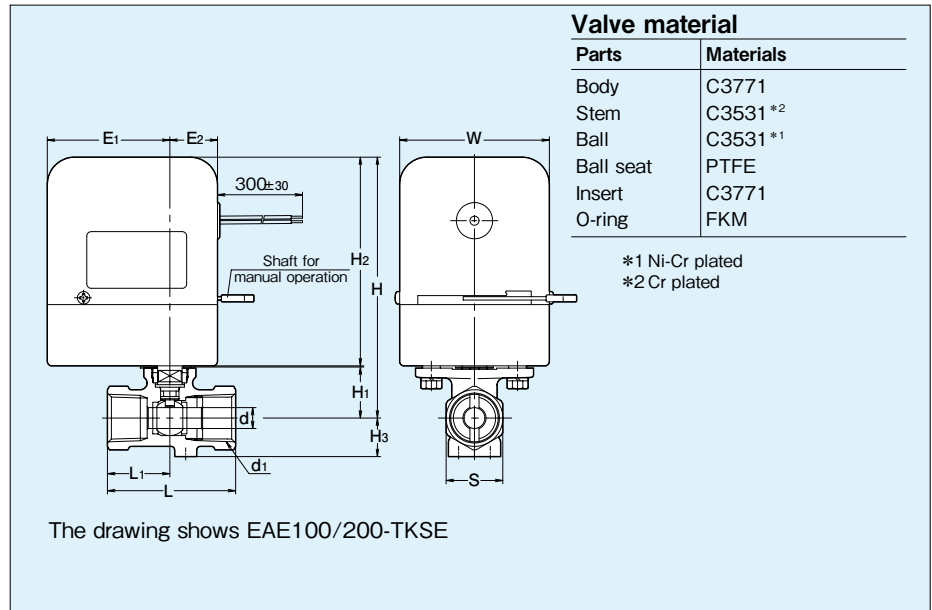

Dimensions

Valve Size (inch)	d	d1	H	H1	H3	L	L1	S	Actuator (mm)				
									H2	E1	E2	W	Type
1/4	5.3	Rc1/4	114.5	21.5	15	44	21	21	92	21	54	66	EAE100/200-1
3/8	7.7	Rc3/8	114.5	21.5	15	44	21	21					
1/2	8	Rc1/2	115.5	22.5	17	56.5	27.5	25					
3/4	11	Rc3/4	118	25	20	59	30	32					

* 5K service pressure for 3/4" TKSE, 1/2" TE and 1/2" TNE. Refer to Page 2 for valve design specifications and PTFE seat pressure-temperature ratings.
 Note: ● Terminal box and cabytre cables are available for option.
 ● EAE actuators are on-off actuators. Do NOT use them for partially opening or closing valves.

⚠ Cautions for use of EAE actuators

- These actuators have no provision of explosion-proof and should not be used in an explosive atmosphere. They have no provision of airtight enclosure and are not recommended for use in corrosive gaseous or excessively humid atmosphere, or where the actuators may get splashed.
- These actuators are designed only for on-off fluid control by means of full opening or closing of valves. Do NOT use them for partial opening or closing for intermediate valve positioning.
- Excessively high frequency of operation such as 20 cycles per hour may shorten service life of actuators. Application to air-conditioning or ventilation service may cause this problem.
- Do NOT use them for handling highly viscous fluids containing particles, dirt or sands.
- Actuator housings are made of PBT resin. To avoid damage, do NOT place any other heavy objects on actuators, or do NOT step on actuators.

Type ED Electric Actuators/Class 10K Bronze or Stainless Steel Ball Valves

12/24V DC

■ **DC 12V or 24V for handy, on-the-spot automated valve operation**

Type ED actuator design specifications

Specification \ Type	ED12-1	ED24-1	ED12-2	ED24-2
Power source 50/60Hz	12V DC	24V DC	12V DC	24V DC
Rated current	360mA	140mA	520mA	260mA
Starting current	0.4A	0.5A	1.9A	0.95A
Max. power consumption	5W	4W	9W	10W
Valve closing time 90°/50Hz	Approx. 5 sec.			
Max. output torque	1.4 N·m		7.3 N·m	
Rated time	5 min			
Insulation Class	JIS Class E			
Position limit switch	One unit each for opening/closing (Voltage output)			
Insulation strength	250V DC (1 min. interval)		500V DC (1 min. interval)	
Insulation resistance	Minimum 10MΩ (250V DC)			
Standard protection	All weather type (for outdoor use, avoid exposure to direct sunlight)			
Ambient temperature	-20°C to +50°C			
Mounting position	Vertical to horizontal			
Wiring	Vinyl cabtyre cord with five cores		UL approved noninflammable cord with five cores	
	0.3mm ²		0.5mm ²	
Lubrication	Grease			
Overload protection	Impedance protection		Thermal protection	
Coating color	Housing: black		Cover: light blue	

Note: Type ED12-2 and ED24-2 are optionally available for mobile application.
Do NOT spray high pressure water directly to Type ED actuator during car wash.

Type ED actuator circuit diagrams

(with the valve fully closed)

ED 12/24 Size 1

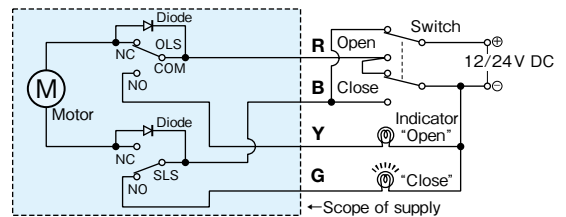

ED 12/24 Size 2

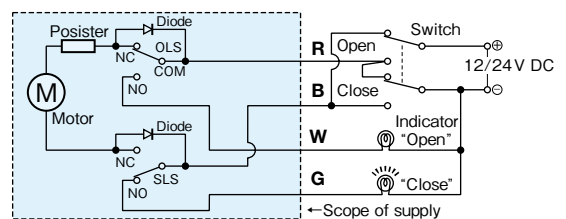

- Wire color: **R** red **W** white **B** black **Y** yellow **G** green
- Actuator rotates:
 - R**⊕ - **B**⊖ : Counter-clockwise to fully open the valve
 - R**⊖ - **B**⊕ : Clockwise to fully close the valve
- Limit switches activate:
 - OLS: on fully opening the valve (R-B: off R-Y(W): on)
 - SLS: on fully closing the valve (R-B: off B-G: on)

Actuator sizing table (ED, EDB Type)

Fig \ Size	1/4	3/8	1/2	3/4	1	1 1/4	1 1/2	2
TE		Type 1			Type 2			
TFE			Type 1	Type 2				
TNE	Type 1				Type 2			
UTE	Type 1			Type 2				
UTFE			Type 1	Type 2				
UTGE	Type 2							
UTNE	Type 1				Type 2			
5/10UTWE		Type 2						

Fig. of actuator-to-valve assemblies

- ED12/24-TE**
- ED12/24-TFE**
- ED12/24-TNE**
- ED12/24-UTE**
- ED12/24-UTFE**
- ED12/24-UTGE**
- ED12/24-UTNE**
- ED12/24-5/10UTWE**

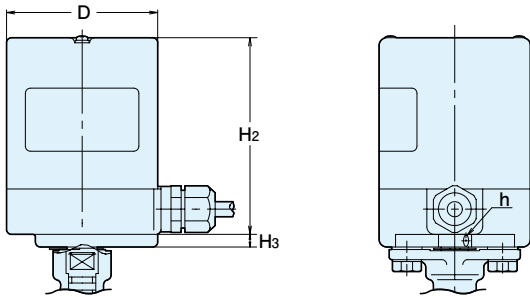

Dimensions of actuator size 1 (mm)

H ₂	H ₃	D	h
78	5	60	4

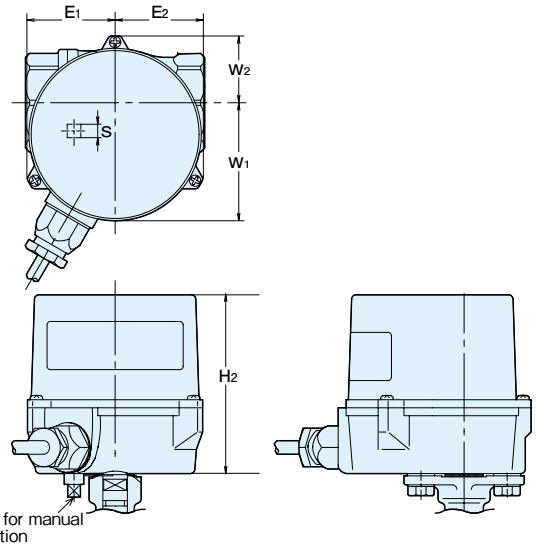

Dimensions of actuator size 2 (mm)

H ₂	E ₁	E ₂	W ₁	W ₂	S
79	39	39	52	30	5.5

Type ES Electric Actuators/Class 10K Brass or Stainless Steel Ball Valves

100/200V AC 50/60Hz

- Shock-resistant and tough polycarbonate (PC) is adopted to the actuator cover and the gear case to improve durability.
- Dust-prevention and drip-proof construction compliant with IP65 ensure the installation in a severe environment.
- Easy separation of valve-actuator assemblies for replacement by hand even in a confined space.
- Semi-translucent actuator cover allows easy viewing of the valve position indicator.
- Downsizing of the product has been achieved by modifications to the layout of the actuator internal parts and the valve connecting structure.
- This product can be installed to the arbitrary location of the intended device using the tapped holes for fixing at the bottom of the valve. Efficiency of piping work is significantly improved, and connection to nylon tubing is easily done.

Type ES actuator design specifications

Specification	Type	ESA100-1	ESA200-1
Operation		ON-OFF (Fully open ⇔ Fully closed)	
Power source (single phase) 50/60Hz		100V AC ± 10%	200V AC ± 10%
Rated current		90mA	50mA
Valve open/closing time		Approx. 9 s (50 Hz)	Approx. 7.5 s (60 Hz)
Rated time		30%ED (Maximum continuous operation time: 10 min)	
External output		One each for opening/closing	
Insulation class		Class E	
Insulation strength		1 min./1500V AC or 1 s/1800V AC	
Insulation resistance		10MΩ or more (500V DC)	
Service environment		Indoor use only (No direct exposure to the sunlight) -20°C to +50°C (No freezing)	
Mounting orientation		Vertical to horizontal	
Overload protection		Impedance protection	
Cable specification	Connection	Cable connection	
	Cable	0.5SQ, six cores, Length: 500mm	
Body material		PC, PPS	
Protection rate		Equivalent to IP65 of IEC60529	
Dismounting of actuator		Removal of two fixing pins	
Manual operation		Removal of actuator	
Compliance with RoHS		ESA□00-UTASE (SCS13A valves): Standard	

Type ES actuator circuit diagrams

(with the valve fully closed)

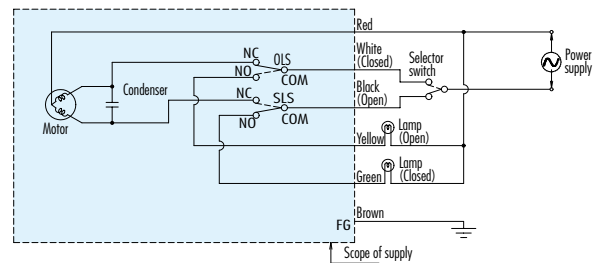

- * Wire color: R red, W white, B black, Y yellow, G green, Br brown
- * Valve in the fully closed position is shown in the circuit diagram above.
- * In the case where yellow cable or green cable is not loaded for connection, do NOT connect them. Please insulate them individually.
- * Ground the product to prevent an electric shock.

Type ES Electric Actuators/Class 10K Brass or Stainless Steel Ball Valves

Fig. of actuator-to-valve assemblies

ESA100/200-TASE
ESA100/200-UTASE



The photo shows ESA100/200-TASE

Valve material

Parts	Materials	
	ESA□00-TASE	ESA□00-UTASE
Body	C3771	SCS13A
Stem	C3531+Cr plated	SUS316+Ni-Cr plated
Ball	C3771+Ni-Cr plated	SUS316
Insert	C3771	SUS316: 1/2B SUS14A: 3/4B, 1B
Ball seat	PTFE	
O ring	FKM	
Bolt	SUS304	

Dimensions

(mm)

Valve Size (inch)	Cv	d	d ₁	H	H ₁	L	L ₁	L ₂	L ₃	S ₁	M ₁	M ₂	Actuator				
													H ₂	L ₄	L ₅	L ₆	W
1/2	5	9.2	Rc1/2	77.3	17	56.5	27.5	14	14	25	115	98					
3/4	10	12.5	Rc3/4	79.8	20	59	30	17	16	32	120	100	61.5	74.5	42	500	61.5
1	15	16	Rc1	83	23	71	36	20	18	38	126	103					

Type RD Electric Compact Proportional Control Valves

24V DC

- **Rotary control type.**
- **Suitable for proportional control with high accuracy.**

Type RD actuator design specification

Specification	Type	Low cost & High durability type	External output type
		RDP224	RDH124
Power supply		DC24 ± 10%	
Rated current		300mA	Operation:1A Stopping:0.1A
Valve closing time (s)		Approx. 15	Selectable between 3 to 20 seconds (Default: 3 seconds) Inching motion for 4 seconds or above
Rated output torque (N · m)		—	8
Max. output torque (N · m)		10	10
Power consumption		8VA	24W
Rated time (Duty factor)		Continuous	
Insulation class		JIS C4003 Class E (120°C)	
Protection rates		Equivalent to IP54	Equivalent to IP55
Service environment		- 10 to + 50°C RH30 to 85% (Indoor use only with no direct sunlight)	
Control input signal (Input impedance)		4 to 20mADC (Impedance 250 Ω)	4 to 20mADC (Impedance 250 Ω) <Option: 1 to 5VDC (Impedance 10k Ω) / 2 to 10VDC (Impedance 10k Ω) >
Position indicator output signal		—	4 to 20mADC(Load resistance Max. 500 Ω) <Option: 1 to 5VDC(Load resistance Min. 100k Ω) >
Error output		—	Open corrector output 30VDC 100mA or below
Dead band		1%	—
Resolution		1/200 minimum	Selectable between 1/10 to 1/200 (Default: 1/200)
Insulation strength		1 second for 600VAC	1 minutes for 250VAC or 1 second for 300VAC Leakage current: 1mA or below
Insulation resistance		500VDC 10M Ω or above	
Mounting position		Vertical to horizontal (No downward)	
Wiring		VCTF 0.3sq x 4c / 1m	Terminal connection 8pins with spring expression connector
Manual operation		Manual operation shaft located on bottom of actuator	Manual operation that turned on power supply is button switch
Position indicator		Indicator plate	LED (4 digits)
Reset operation		Power supply	Switches on operation panel (OPEN, SHUT or AUTO/MANUAL) or power off
Malfunction detection		—	Restriction error, Hunting error
Action		Reverse action	Selectable between direct action and reverse action (Default: Reverse action)
Operation at input signal interruption		Fully closed	Selectable from Fully closed/Fully open/Stop (Default: Fully closed)
Operation after power recovery		Control starts after fully closed	Control starts from where the power was cut off.
Lubricant		Grease	
Overload protection		—	Build-in current limiter circuit
Painting color		Black housing with light blue cover	

Type RD wiring diagram

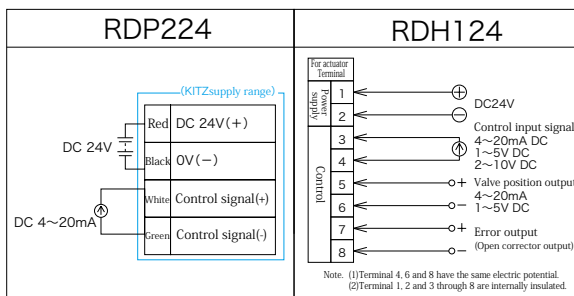

Flow Characteristics

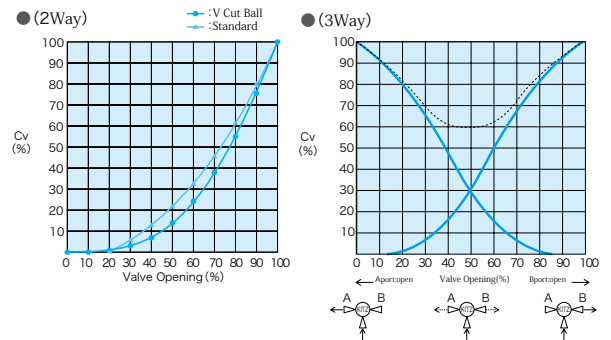

Terminal box(RDH124)

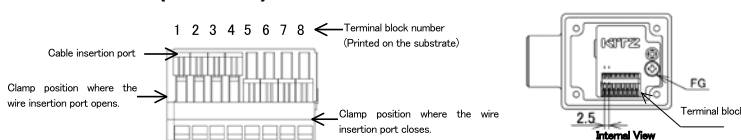

Number of Wire Cores	Applicable Electric Wire	Solid Wire	Flexible Stranded Wire	Exposed Length
8	AWG28 to AWG20	0.08 to 0.5mm ²	0.25mm ²	5 to 6mm

Low cost & High durability type

Fig of actuator - to-valve assemblies *EU RoHS

RDP224-TE
RDP224-TQE
RDP224-TKLVE

RDP224-TFE
RDP224-TKLQSE
RDP224-UTKLVEM*

RDP224-UTE*
RDP224-UTQE*

RDP224-UTFE*

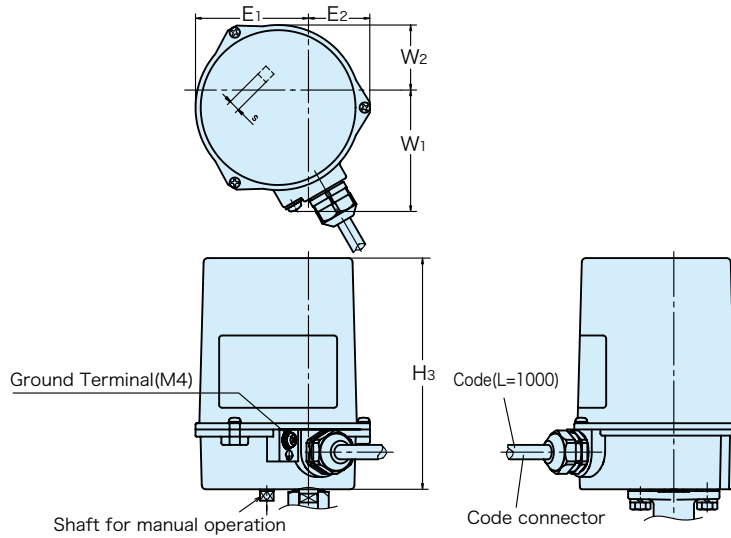

H ₃	E ₁	E ₂	W ₁	W ₂	S
108.5	54.5	30	59	31.5	5.5

External output type

Fig of actuator - to-valve assemblies *EU RoHS

RDH124-TE
RDH124-UTFE*
RDH124-TKLVE

RDH124-TFE
RDH124-TQE
RDH124-UTKLVEM*

RDH124-TNE
RDH124-TKLQSE

RDH124-UTE*
RDH124-UTQE*

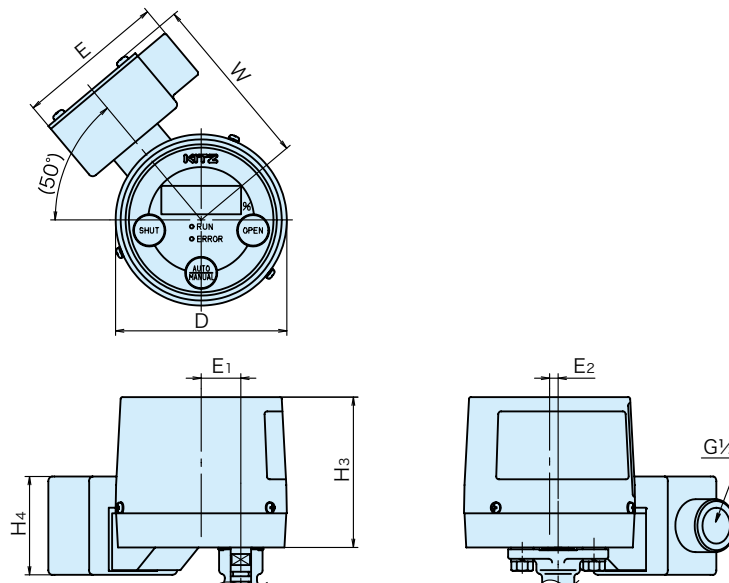

H ₃	H ₄	D	E	E ₁	E ₂	W
79.5	52	90.5	79	21	4.5	92.5

Type LDP Electric Compact Proportional Control Valves

24V DC

- **Linear control type.**
- **Coolant flow control use of semiconductor production device.**

Type LDP actuator design specification

Actuator size	LDP224
Power supply	DC24 ± 10%
Rated current	Operation:600mA Stopping:50mA
Inrush current	5A
Valve closing time (s)	Approx. 5
Power consumption (W)	14.4W
Max. output torque (N · m)	—
Duty factor (%ED)	27.8%ED
Insulation class	JIS C4003 Class E
Protection rates	Equivalent to IP54 except air vent
Service environment	0 to + 50°C RH30 to 85% (Indoor use only with no direct sunlight)
Control input signal	4 to 20mADC
Input impedance	230 Ω
Output signal	—
Manual position setting	—
Position indicator	—
Reset operation	—
Dead band	± 0.3%
Resolution	1/300 minimum
Hysteresis	Max. 1% (FS)
Insulation strength	1 minutes for 500VAC or 1 second for 600VAC Leakage current: 0.1mA or below
Insulation resistance	500VDC 20M Ω or above
Wiring	Non-flammable cord (UL style2464)
Mounting position	Vertical to horizontal (No downward)
Action	Reverse action
Operation at signal interruption	Fully closed
Operation after power recovery	Control starts after fully closed
Overload protection	Build in thermal protection
Painting color	Black housing with light blue cover

LD Connecting diagram

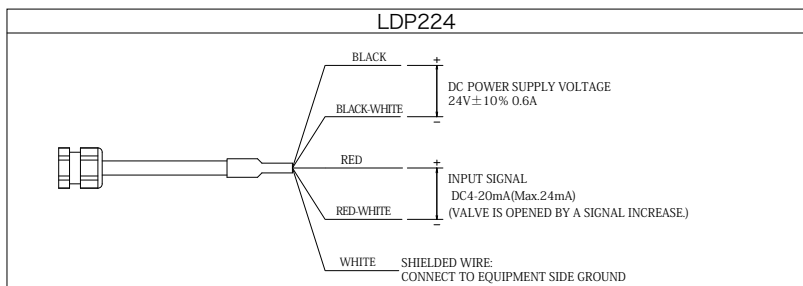

Flow characteristics

- UNLE
- 1/4" B, 3/8" B

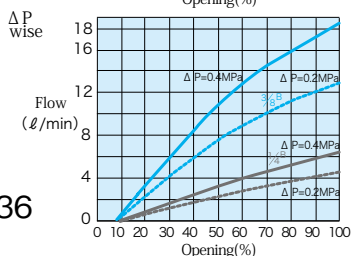
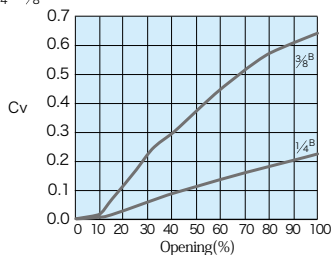

High accuracy electric Compact proportionate control needle valve

Fig of actuator - to - valve assembly

LDP224-UNLE

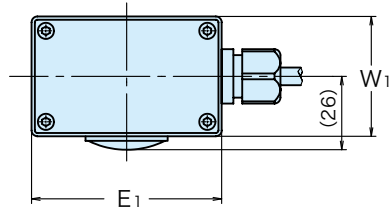

Valve material

Parts	Materials
Body	SCS14A / 316SS(size $\frac{1}{2}$ "~)
Stem	316SS
Seating	316SS
O-ring	FKM
Stem guide	PPS
Spring	SUS304+WPB

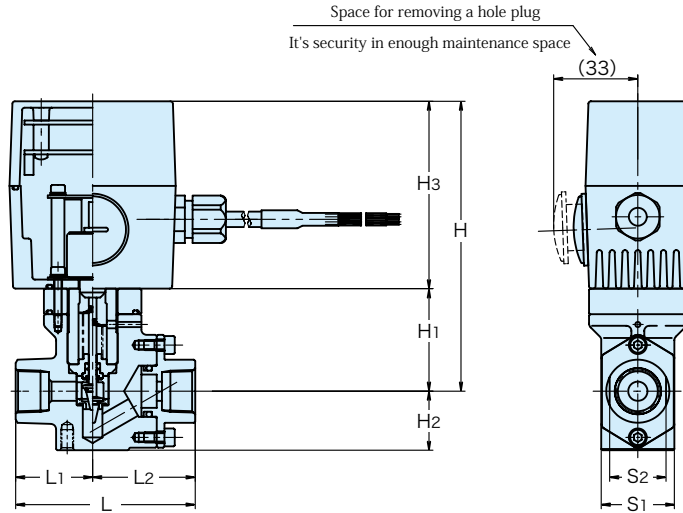

Dimensions

(mm)

Valve Size	H	H ₁	H ₂	L	L ₁	L ₂	S ₁	S ₂	Actuator		
									H ₃	E ₁	W ₁
$\frac{1}{4} \cdot \frac{3}{8}$	113	40	23	70	30	40	28.5	22	73	65	41

Precautions for Trouble-free Operation of Electric Actuator Driven Ball Valves

Storage and Handling

Electrically operated KITZ compact ball valves are individually packed in styrofoam boxes. Do NOT unpack until you are ready to mount on the pipeline; store in dry, corrosion-free environment to keep rust-free, although they are adequately coated for primary protection. Handle units carefully when actuators are equipped with solenoid valves and other accessories. Do NOT place any other objects on actuators, and do NOT step on actuators. Overloading actuators must always be prevented.

Mounting and Piping

Before mounting electrically operated KITZ compact ball valves, make visual inspection of all valves, actuators and accessories to assure trouble-free condition. Tighten any loosened bolts securely. Clean valve and pipe bores to remove welding spatters, scales or any other foreign objects that may have been left inside. After mounting has been completed, blow the inside of all connected pipes and valves prior to the pilot operation of the system.

Do NOT use them in explosive or corrosive gaseous conditions, to avoid explosions, or damage to terminal contacts.

If there are materials containing silicon in the surrounding environment, a contact failure may occur due to the generation of siloxane gas. Do NOT use the product in a siloxane gas atmosphere.

Wiring and Operation

Color-coded wires should be connected to each correct terminal according to the actuator circuit diagram shown on each page of this catalog. Incorrect wiring may damage electrical components and accessories.

The following actuator is not provided with built-in relays. For parallel operation with other actuators, be sure to deploy a separate relay for each valve to drive.

EA	EAL	EAH	EAE	ED	ES
EAB	EALB	EAHB			

When valve opening or closing indicator lamp is not required, cut the exposed part of the wire end and isolate it from the electric current. Before manual operation, be sure to turn off the switch.

Do NOT use silicon-containing materials (electric wire, filler, adhesive) when wiring. It may result in a contact failure due to the generation of siloxane gas.

Maintenance

Disassembly of actuators is not recommended. Electrically operated KITZ compact ball valves can be mounted vertically, horizontally or with any intermediate angle as illustrated here. However, do NOT mount any lower than the horizontal level, as intrusion of rainwater may affect the quality of electric components and accessories.

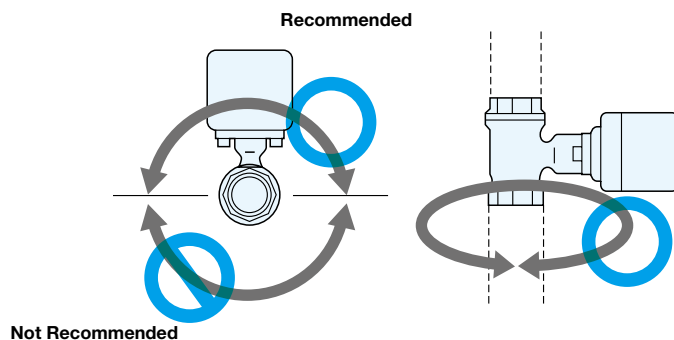

Design Features of KITZ C·CS/FBS Series Actuators

- Lightweight and compact size
Die-casted aluminum body and double piston mechanism make the actuator lightweight and compact.
- Simple mechanism and less malfunction
This actuator consists of minimum number of parts. That makes the actuator longer service life and less possibility of malfunction.
- Special solenoid valve
Direct mount type special solenoid valve exclusively used for KITZ C-type actuator is available.
- Highly efficient quarter turn actuator
Double piston type rack and pinion mechanism provides highly efficient quarter turn rotation.
- Direct mount type
The actuator is directly mounted on a valve with only two bolts.

FBS-type actuator should be chosen for bigger size valves.

Standard guide actuator selection (C, CS, FBS Type)

Fig	Size	1/4"	3/8"	1/2"	3/4"	1"	1 1/4"	1 1/2"	2"
TE		C-1				C-2			
		CS-1	CS-2			(FBS-1)			
TFE		C-1			C-2				
		CS-2	(FBS-1)						
TLE		C-1				C-2			
		CS-2				(FBS-1)			
TUE		C-1			C-2				
		CS-2			(FBS-1)				
TNE		C-1				C-2			
		CS-1	CS-2			(FBS-1)			
UTE		C-1				C-2			
		CS-1	CS-2			(FBS-1)			
UTFE		C-1			C-2				
		CS-2	(FBS-1)						
UTGE		C-1		C-2					
		CS-2		(FBS-1)					
UTNE		C-1				C-2			
		CS-1	CS-2			(FBS-1)			
5/10UTWE		C-1			C-2				
		CS-2			(FBS-1)				
UTKLAHE <J0J05>		C-2							
		CS-2							

For the size ranges not covered by KITZ C Series actuators, more powerful KITZ Type FBS-1 actuators are recommended.

KITZ C·CS Series Pneumatic Actuators

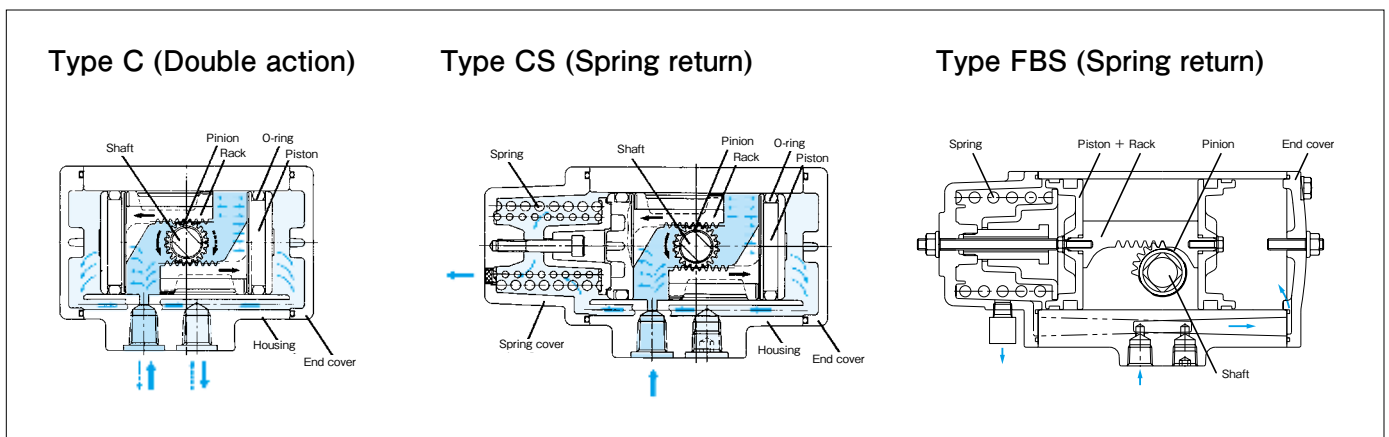

Types EA · EAB

Types EAL · EALB

Types EAH · EAHB

Type EAE

Type ED

Type ES

Types C·CS/FBS

Actuator design Specifications

Specification \ Type	C-1	C-2	CS-1	CS-2	FBS-1
Operating media	Instrumentation air				
Standard operating pressure	0.4 MPa (60 psi)				
Operating pressure range	0.4-0.7 MPa (60-100 psi)				0.3-0.7 MPa (43-100 psi)
Output torque *1	3.9 N·m	8.5 N·m	1.3 N·m	3.1 N·m	7.6 N·m
Housing shell test pressure	1.0 MPa (140 psi)				
Angle of revolution	90° (+1° to +5°)				90° ±7°
Cylinder volume (Liter)	0.073	0.160	0.033	0.071	0.15
Operation time	Max. 1 s*4				
Service temperature range *2	-20°C to +60°C -4°F to +140°F				-20°C to +80°C -4°F to +176°F
Ambient condition *3	Indoor				

Notes:

- *1 At supply pressure, 0.4 MPa
- *2 Free from freezing of supply air
- *3 For outdoor service, consult a KITZ Engineer
- *4 On a condition of KITZ standard air equipment and no load on a valve

KITZ Standard Accessories

C-type actuator has a direct mount-type special solenoid valve. It makes piping-less and compact mounting. This special solenoid valve is not waterproof type. Prevent water if you use them outdoor.

◆ **Special Solenoid Valve**

Electrical connection	Lead wire type
Working pressure range	0.15 to 0.7 MPa
Ambient temperature range	5 to 50°C
Air inlets	Rc1/8
Effective area of valve	4.0mm ²
Power supply	AC100, 110V/50, 60Hz:±10% AC200, 220V/50, 60Hz:±10% DC24:±10%

◆ **Limit Switch**

Sensing position	One position
Power supply	AC: 5 A-125V AC 5 A-250V AC DC: 0.5A-115V DC 0.25 A-230V DC
Ambient temperature range	-10 to 70°C
Electrical connection	Conduit type
Electric wire diameter	φ5.8 to φ7.8

◆ **Filter-Regulator**

Structure	Relief type
Working pressure range	0.04 to 0.83MPa
Ambient temperature range	5 to 65°C
Nominal filtration rating	5μm
Air inlets	Rc1/4"

◆ **Silencer**

Connection	Rc1/8
Effective area	15mm ²
Noise reduction	18dB
Maximum working pressure	0.9MPa
Ambient temperature range	5 to 60°C

◆ **Speed Controller**

Structure	Restrictor	Exhaust restrictor	Exhaust restrictor with silencer
Working pressure range	0.05 to 1MPa	0.1 to 1MPa	0 to 1MPa
Ambient temperature range	5 to 60°C	-5 to 60°C	0 to 60°C
Air inlets	Rc1/8"	R1/8"·Rc1/8"	Rc1/8"

Type C Pneumatic Actuators/Class 10K Bronze Ball Valves

Fig. C-TE
(Standard bore)

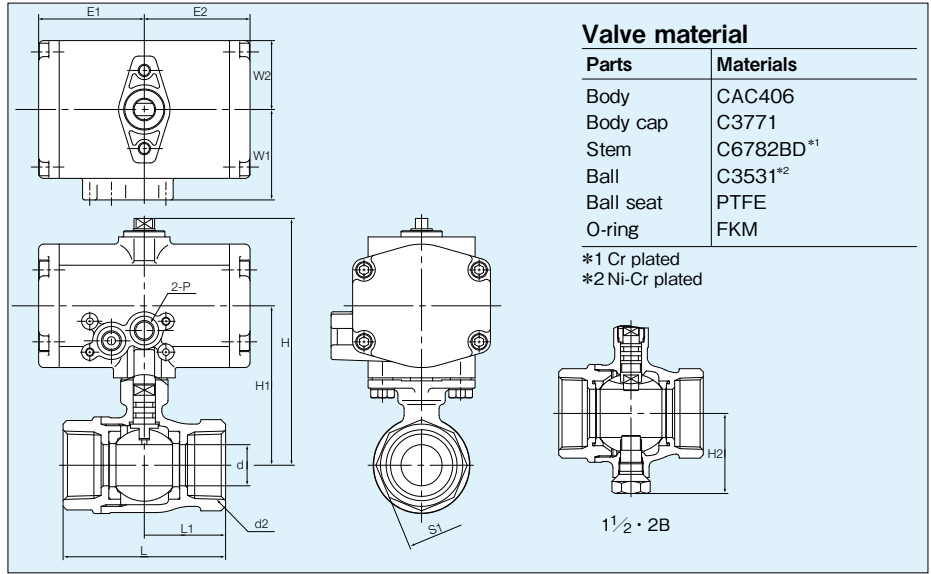

Valve material

Parts	Materials
Body	CAC406
Body cap	C3771
Stem	C6782BD*1
Ball	C3531*2
Ball seat	PTFE
O-ring	FKM

*1 Cr plated
*2 Ni-Cr plated

1 1/2 · 2B

Dimensions

Valve Size (inch)	d	d ₂	H	H ₁	H ₂	L	L ₁	S ₁	Actuators					
									E ₁	E ₂	W ₁	W ₂	P	Type
3/8	7.5	Rc3/8	87.5	56	—	46	22	22	43	43	34.5	26	Rc1/8	C-1
1/2	10	Rc1/2	93.5	62	—	65	32.5	28						
3/4	15	Rc3/4	97.5	66	—	68	34	34						
1	20	Rc1	101.5	70	—	79	39.5	41	51.4	51.4	44	33.5	Rc1/8	C-2
1 1/4	25	Rc1 1/4	124.5	82	—	86	43	50						
1 1/2	32	Rc1 1/2	137.5	95	53.5	96	48	56						
2	40	Rc2	144.5	102	60	109	54.5	68						

(mm)

Type CS/FBS Pneumatic Actuators/Class 10K Bronze Ball Valves

Fig. CS-TE
Valve size: 3/8" to 1"
FBS-TE
Valve size: 1 1/4" to 2"
(Standard bore)

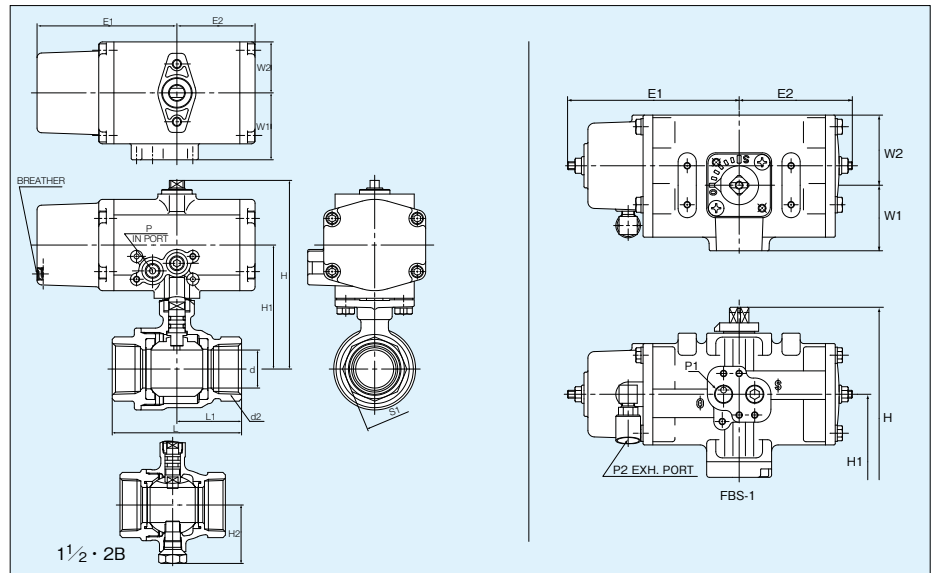

Dimensions

Valve Size (inch)	d	d ₂	H	H ₁	H ₂	L	L ₁	S ₁	Actuators						
									E ₁	E ₂	W ₁	W ₂	P ₁	P ₂	Type
3/8	7.5	Rc3/8	87.5	56	—	46	22	22	69.5	43	34.5	26	—	Rc1/8	CS-1
1/2	10	Rc1/2	112.5	70	—	65	32.5	28							
3/4	15	Rc3/4	116.5	74	—	68	34	34							
1	20	Rc1	120.5	78	—	79	39.5	41	92	51.4	44	33.5	—	Rc1/8	CS-2
1 1/4	25	Rc1 1/4	182	112	—	86	43	50							
1 1/2	32	Rc1 1/2	195	125	53.5	96	48	56							
2	40	Rc2	202	132	60	109	54.5	68	132	87	50	54	Rc1/4	Rc1/8	FBS-1

(mm)

Type C Pneumatic Actuators/Class 10K Copper Alloy Ball Valves, Full Bore

Fig. C-TFE
(Full bore)

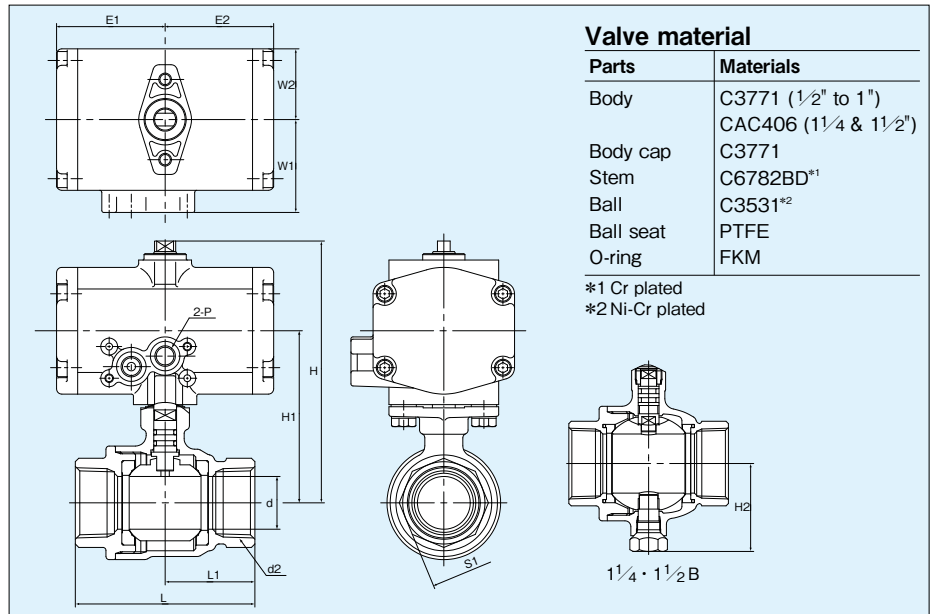

Valve material

Parts	Materials
Body	C3771 (1/2" to 1") CAC406 (1 1/4 & 1 1/2")
Body cap	C3771
Stem	C6782BD*1
Ball	C3531*2
Ball seat	PTFE
O-ring	FKM

*1 Cr plated
*2 Ni-Cr plated

Dimensions

Valve Size (inch)	d	d ₂	H	H ₁	H ₂	L	L ₁	S ₁	Actuators						
									E ₁	E ₂	W ₁	W ₂	P	Type	
1/2	15	Rc1/2	97.5	66	—	63	31.5	26							
3/4	20	Rc3/4	101.5	70	—	73	36.5	32	43	43	34.5	26	Rc1/8	C-1	
1	25	Rc1	124.5	82	—	85	42.5	39							
1 1/4	32	Rc1 1/4	138.5	96	53.5	98	49	50	51.4	51.4	44	33.5	Rc1/8	C-2	
1 1/2	40	Rc1 1/2	144.5	102	59.5	108	54	56							

(mm)

Type CS/FBS Pneumatic Actuators/Class 10K Copper Alloy Ball Valves, Full Bore

Fig. CS-TFE
Valve size: 1/2"
FBS-TFE
Valve size: 3/4" to 1 1/2"
(Full bore)

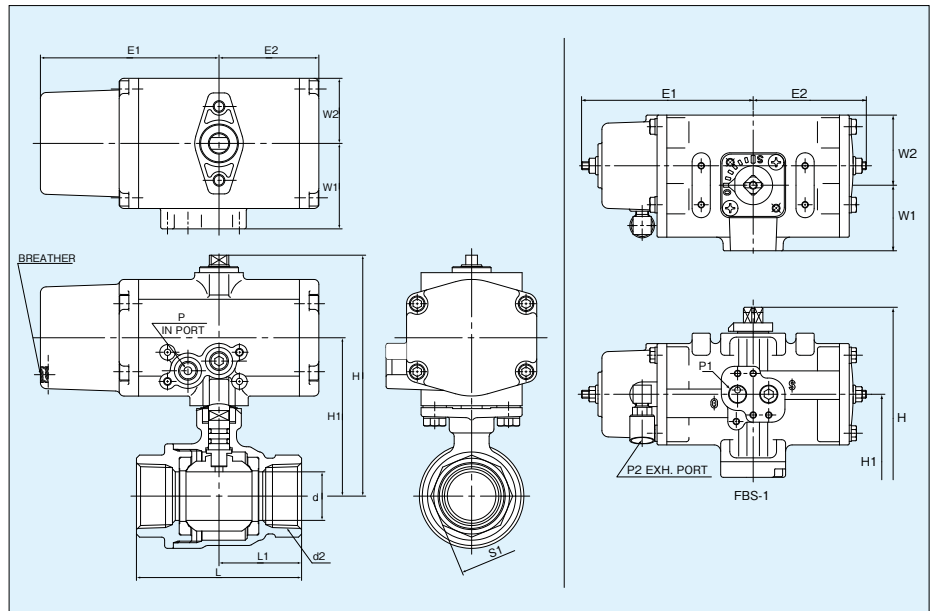

Dimensions

Valve Size (inch)	d	d ₂	H	H ₁	H ₂	L	L ₁	S ₁	Actuators						
									E ₁	E ₂	W ₁	W ₂	P ₁	P ₂	Type
1/2	15	Rc1/2	108.5	66	—	63	31.5	26	92	51.4	44	33.5	—	Rc1/8	CS-2
3/4	20	Rc3/4	178	108	—	73	36.5	32							
1	25	Rc1	182	112	—	85	42.5	39							
1 1/4	32	Rc1 1/4	196	126	53.5	98	49	50	132	87	50	54	Rc1/4	Rc1/8	FBS-1
1 1/2	40	Rc1 1/2	202	132	59.5	108	54	56							

(mm)

Type C Pneumatic Actuators/Class 10K Long Neck Bronze Ball Valves

Fig. **C-TLE**
(Standard bore)

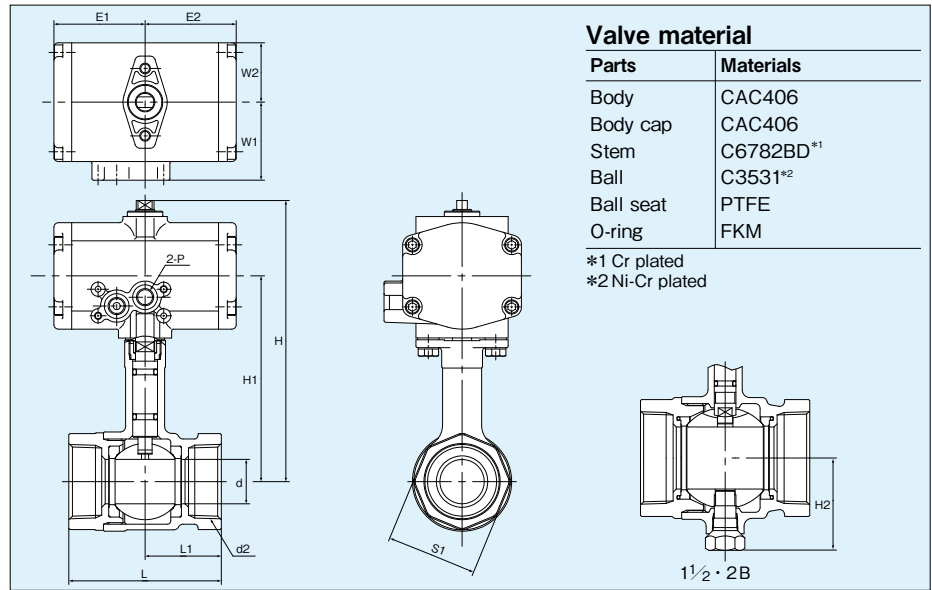

Valve material

Parts	Materials
Body	CAC406
Body cap	CAC406
Stem	C6782BD*1
Ball	C3531*2
Ball seat	PTFE
O-ring	FKM

*1 Cr plated
*2 Ni-Cr plated

Dimensions

Valve Size (inch)	d	d ₂	H	H ₁	H ₂	L	L ₁	S ₁	Actuators					
									E ₁	E ₂	W ₁	W ₂	P	Type
1/2	10	Rc1/2	115.5	84	—	56	28	27	43	43	34.5	26	Rc1/8	C-1
3/4	15	Rc3/4	120.5	89	—	65	32.5	33						
1	20	Rc1	123.5	92	—	78	39	41						
1 1/4	25	Rc1 1/4	158.5	116	—	86	43	51	51.4	51.4	44	33.5	Rc1/8	C-2
1 1/2	32	Rc1 1/2	161.5	119	53.5	96	48	58						
2	40	Rc2	168.5	125	60	109	54.5	71						

Type CS / FBS Pneumatic Actuators/Class 10K Long Neck Bronze Ball Valves

Fig. **CS-TLE**
Valve size: 1/2" to 1"
FBS-TLE
Valve size: 1/4" to 2"
(Standard bore)

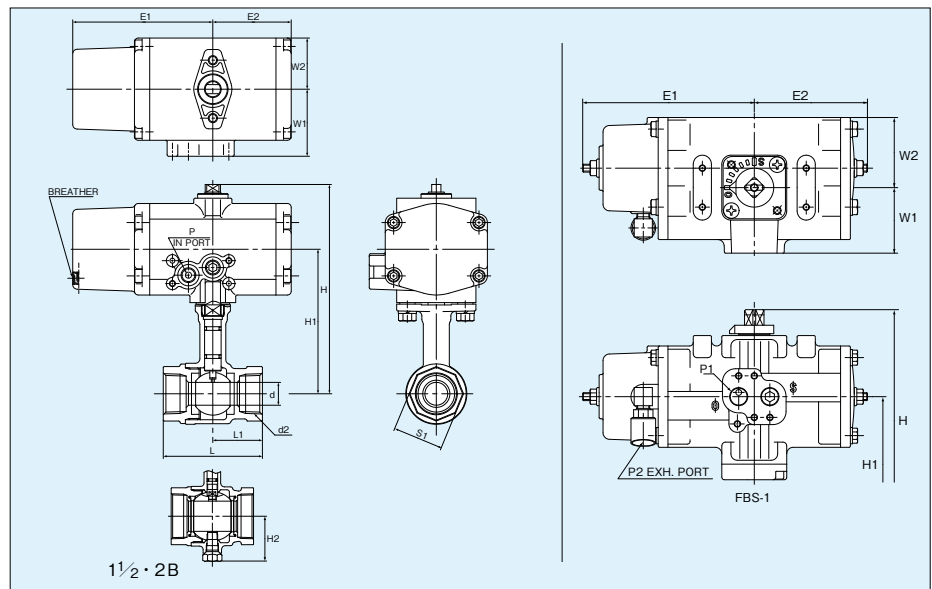

Dimensions

Valve Size (inch)	d	d ₂	H	H ₁	H ₂	L	L ₁	S ₁	Actuators						
									E ₁	E ₂	W ₁	W ₂	P ₁	P ₂	Type
1/2	10	Rc1/2	134.5	92	—	56	28	27	92	51.4	44	33.5	—	Rc1/8	CS-2
3/4	15	Rc3/4	139.5	97	—	65	32.5	33							
1	20	Rc1	142.5	100	—	78	39	41							
1 1/4	25	Rc1 1/4	215	145	—	86	43	51	132	87	50	54	Rc1/4	Rc1/8	FBS-1
1 1/2	32	Rc1 1/2	218	148	53.5	96	48	58							
2	40	Rc2	226	156	60	109	54.5	71							

Types C-CS/FBS

Type C Pneumatic Actuators/Class 10K Horizontal 3-way Bronze Ball Valves

Fig. **C-TNE**
(Standard bore)

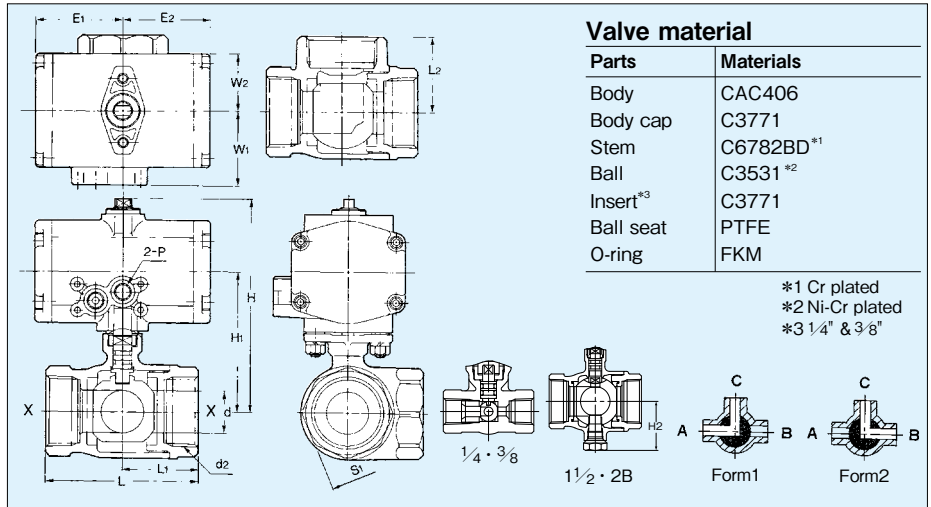

Note: Refer to page 3 for flow directional forms.

Products are adequately identified with nameplates indicating either one Form 1 or Form 2.

Dimensions

Valve Size (inch)	d	d ₂	H	H ₁	H ₂	L	L ₁	L ₂	S ₁	Actuators					
										E ₁	E ₂	W ₁	W ₂	P	Type
1/4	4.5	Rc1/4	85.5	54	—	46	23	23	21	43	43	34.5	26	Rc1/8	C-1
3/8	6.8	Rc3/8	85.5	54	—	46	23	23	21						
1/2	10	Rc1/2	93.5	62	—	67	33.5	33.5	28						
3/4	15	Rc3/4	97.5	66	—	68	34	34	34						
1	20	Rc1	101.5	70	—	79	39.5	39.5	41	51.4	51.4	44	33.5	Rc1/8	C-2
1 1/4	25	Rc1 1/4	125.5	83	—	89	44.5	44.5	50						
1 1/2	32	Rc1 1/2	138.5	96	53.5	100	50	50	56						
2	40	Rc2	144.5	102	60	115	57.5	57.5	68						

Type CS/FBS Pneumatic Actuators/Class 10K Horizontal 3-way Bronze Ball Valves

Fig. **CS-TNE**
Valve size: 1/4" to 1"
FBS-TNE
Valve size: 1/4" to 2"
(Standard bore)

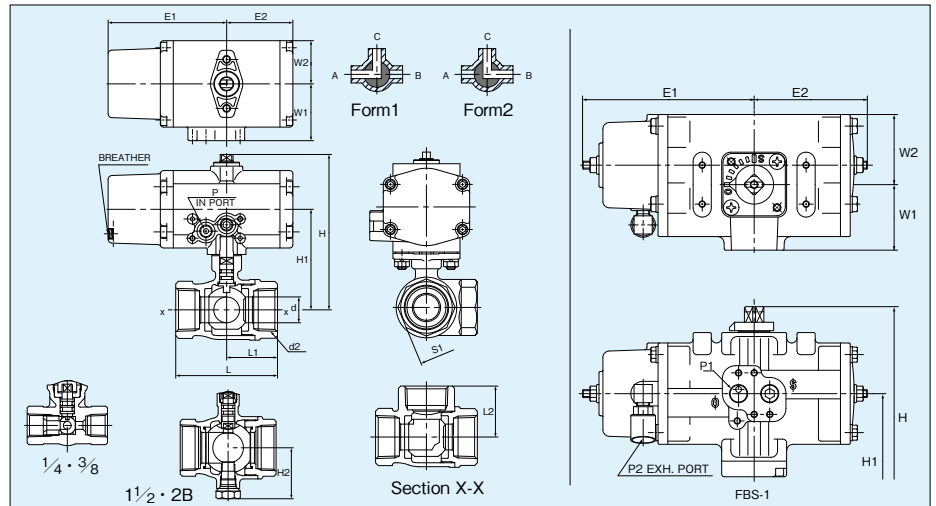

Note: Refer to page 3 for flow directional forms.

Products are adequately identified with nameplates indicating either one Form 1 or Form 2.

Dimensions

Valve Size (inch)	d	d ₂	H	H ₁	H ₂	L	L ₁	L ₂	S ₁	Actuators						
										E ₁	E ₂	W ₁	W ₂	P ₁	P ₂	Type
1/4	4.5	Rc1/4	85.5	54	—	46	23	23	21	69.5	43	34.5	26	—	Rc1/8	CS-1
3/8	6.8	Rc3/8	85.5	54	—	46	23	23	21							
1/2	10	Rc1/2	112.5	70	—	67	33.5	33.5	28							
3/4	15	Rc3/4	116.5	74	—	68	34	34	34	92	51.4	44	33.5	—	Rc1/8	CS-2
1	20	Rc1	120.5	78	—	79	39.5	39.5	41							
1 1/4	25	Rc1 1/4	183	113	—	89	44.5	44.5	50							
1 1/2	32	Rc1 1/2	196	126	53.5	100	50	50	56	132	87	50	54	Rc1/4	Rc1/8	FBS-1
2	40	Rc2	202	132	60	115	57.5	57.5	68							

Type C Pneumatic Actuators/Class 10K Union-Nipple Bronze Ball Valves

Fig. **C-TUE**
(Reduced bore)

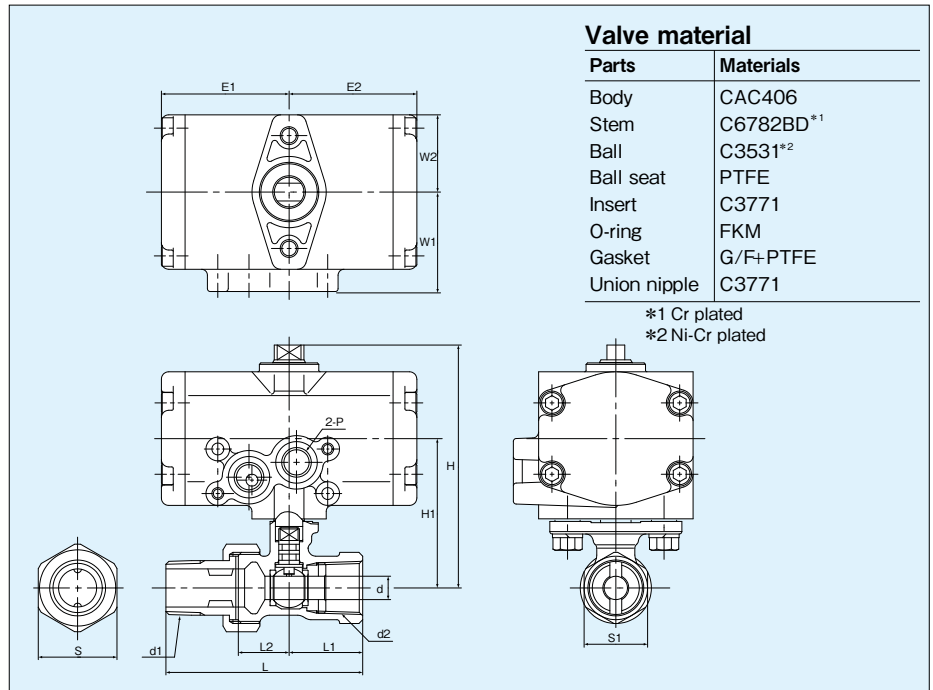

Dimensions

(mm)

Valve Size (inch)	d	d ₂	d ₁	H	H ₁	L	L ₁	L ₂	S	S ₁	Actuators					
											E ₁	E ₂	W ₁	W ₂	P ₂	Type
1/2	8	Rc1/2	R1/2	85.5	54	78.5	29	20	31	25	43	43	34.5	26	Rc1/8	C-1
3/4	11	Rc3/4	R3/4	88.5	57	81	29	20	36	32						

Type CS Pneumatic Actuators/Class 10K Union-Nipple Bronze Ball Valves

Fig. **CS-TUE**
(Reduced bore)

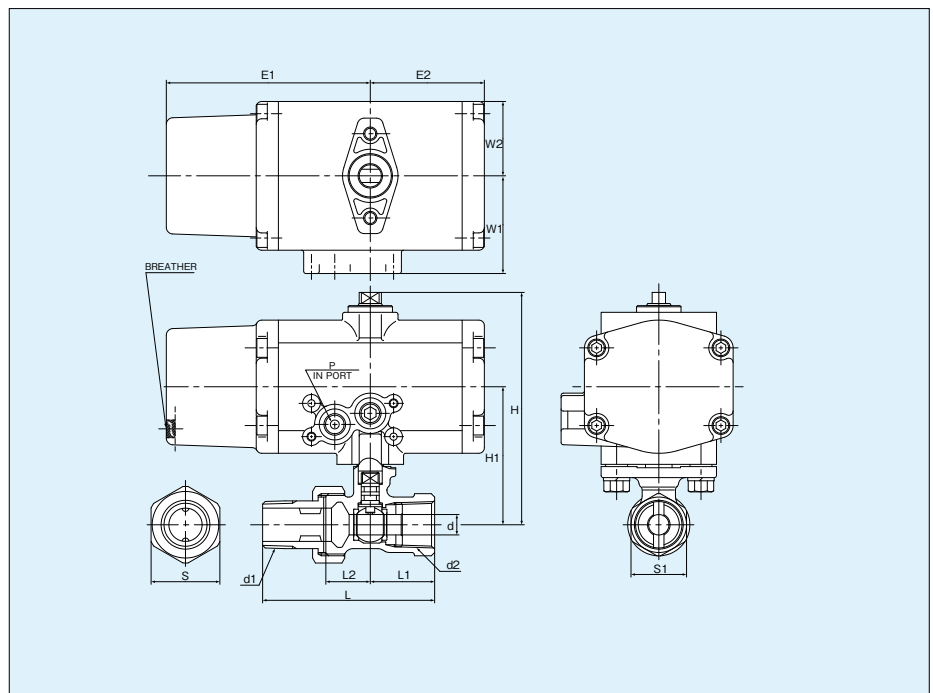

Dimensions

(mm)

Valve Size (inch)	d	d ₂	d ₁	H	H ₁	L	L ₁	L ₂	S	S ₁	Actuators					
											E ₁	E ₂	W ₁	W ₂	P ₂	Type
1/2	8	Rc1/2	R1/2	104.5	62	78.5	29	20	31	25	92	51.4	44	33.5	Rc1/8	CS-2
3/4	11	Rc3/4	R3/4	107.5	65	81	29	20	36	32						

Type C Pneumatic Actuators/Class 10K Stainless Steel Ball Valves

Fig. **C-UTE**
(Reduced bore)

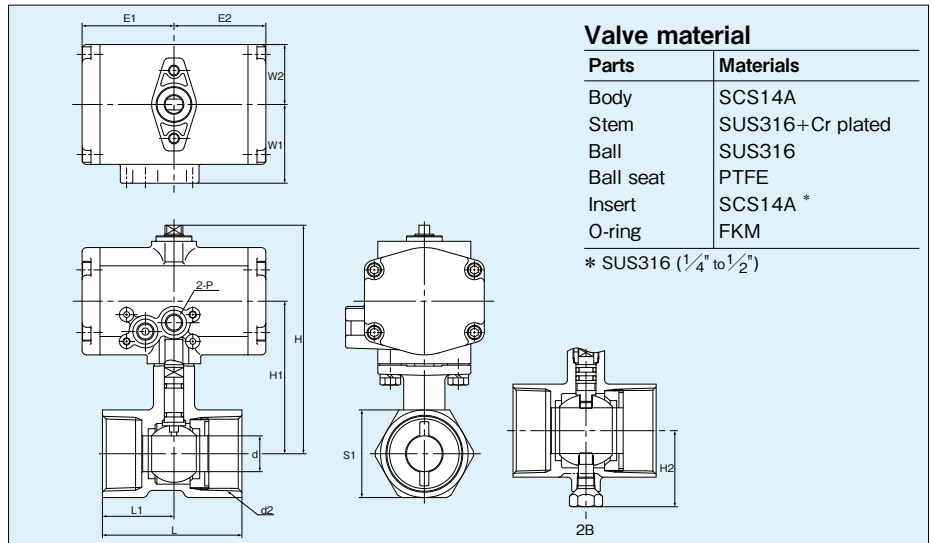

Valve material

Parts	Materials
Body	SCS14A
Stem	SUS316+Cr plated
Ball	SUS316
Ball seat	PTFE
Insert	SCS14A *
O-ring	FKM

* SUS316 (1/4" to 1/2")

Dimensions

Valve Size (inch)	d	d ₂	H	H ₁	H ₂	L	L ₁	S ₁	Actuators					
									E ₁	E ₂	W ₁	W ₂	P	Type
1/4	4.5	Rc1/4	85.5	54	—	44	21	21	43	43	34.5	26	Rc1/8	C-1
3/8	6.8	Rc3/8	85.5	54	—	44	21	21						
1/2	9.2	Rc1/2	85.5	54	—	56.5	27.5	25						
3/4	12.5	Rc3/4	88.5	57	—	59	30	32						
1	16	Rc1	91.5	60	—	71	36	38	51.4	51.4	44	33.5	Rc1/8	C-2
1 1/4	20	Rc1 1/4	128.5	86	—	78	40	49						
1 1/2	24.5	Rc1 1/2	131.5	89	—	83	42.5	53						
2	32	Rc2	137.5	95	53.5	100	51	65						

(mm)

Type CS/FBS Pneumatic Actuators/Class 10K Stainless Steel Ball Valves

Fig. **CS-UTE**
Valve size: 1/4" to 1"
FBS-UTE
Valve size: 1/4" to 2"
(Reduced bore)

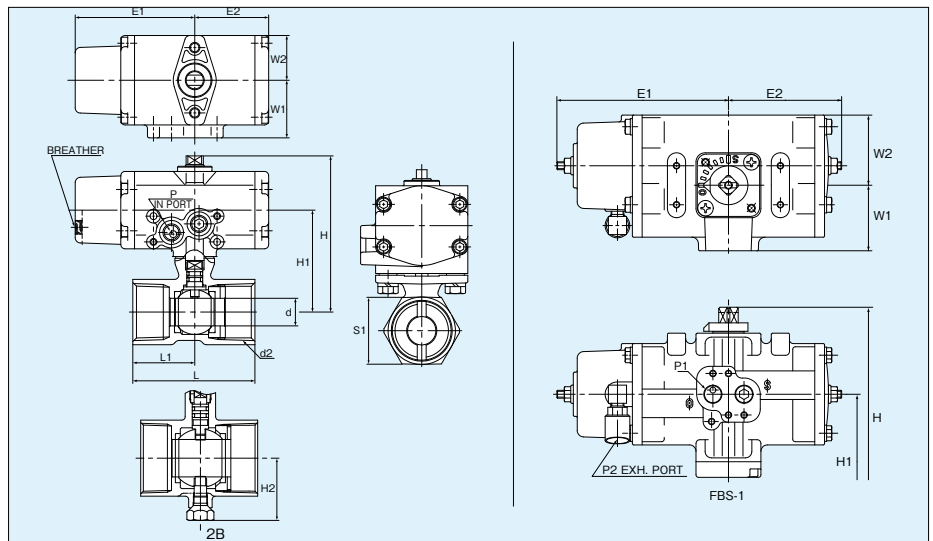

Dimensions

Valve Size (inch)	d	d ₂	H	H ₁	H ₂	L	L ₁	S ₁	Actuators						
									E ₁	E ₂	W ₁	W ₂	P ₁	P ₂	Type
1/4	4.5	Rc1/4	85.5	54	—	44	21	21	69.5	43	34.5	26	—	Rc1/8	CS-1
3/8	6.8	Rc3/8	85.5	54	—	44	21	21							
1/2	9.2	Rc1/2	104.5	62	—	56.5	27.5	25	92	51.4	44	33.5	—	Rc1/8	CS-2
3/4	12.5	Rc3/4	107.5	65	—	59	30	32							
1	16	Rc1	110.5	68	—	71	36	38							
1 1/4	20	Rc1 1/4	186	116	—	78	40	49	132	87	50	54	Rc1/4	Rc1/8	FBS-1
1 1/2	24.5	Rc1 1/2	189	119	—	83	42.5	53							
2	32	Rc2	195	125	53.5	100	51	65							

(mm)

Type C Pneumatic Actuators/Class 10K Stainless Steel Ball Valves, Full Bore

Fig. **C-UTFE**
(Full bore)

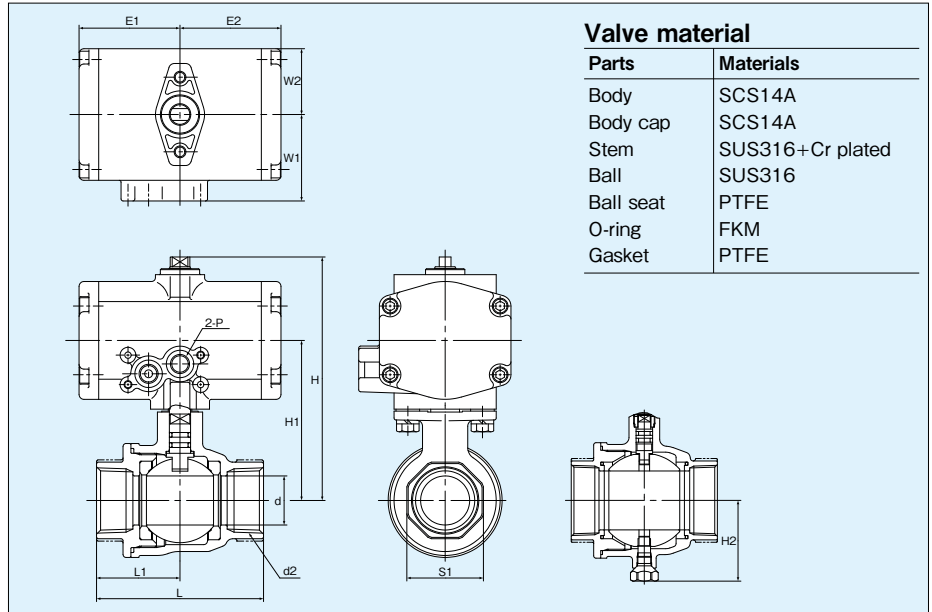

Valve material

Parts	Materials
Body	SCS14A
Body cap	SCS14A
Stem	SUS316+Cr plated
Ball	SUS316
Ball seat	PTFE
O-ring	FKM
Gasket	PTFE

Dimensions

Valve Size (inch)	d	d ₂	H	H ₁	H ₂	L	L ₁	S ₁	Actuators					
									E ₁	E ₂	W ₁	W ₂	P	Type
1/2	15	Rc1/2	97.5	66	—	62	31	26	43	43	34.5	26	Rc1/8	C-1
3/4	20	Rc3/4	101.5	70	—	73	36.5	32						
1	25	Rc1	124.5	82	—	85	42.5	39	51.4	51.4	44	33.5	Rc1/8	C-2
1 1/4	32	Rc1 1/4	138.5	96	55	98	49	48						
1 1/2	40	Rc1 1/2	144.5	102	61	108	54	54						

(mm)

Type CS/FBS Pneumatic Actuators/Class 10K Stainless Steel Ball Valves, Full Bore

Fig. **CS-UTFE**
Valve size: 1/2"
FBS-UTFE
Valve size: 3/4" to 1 1/2"
(Full bore)

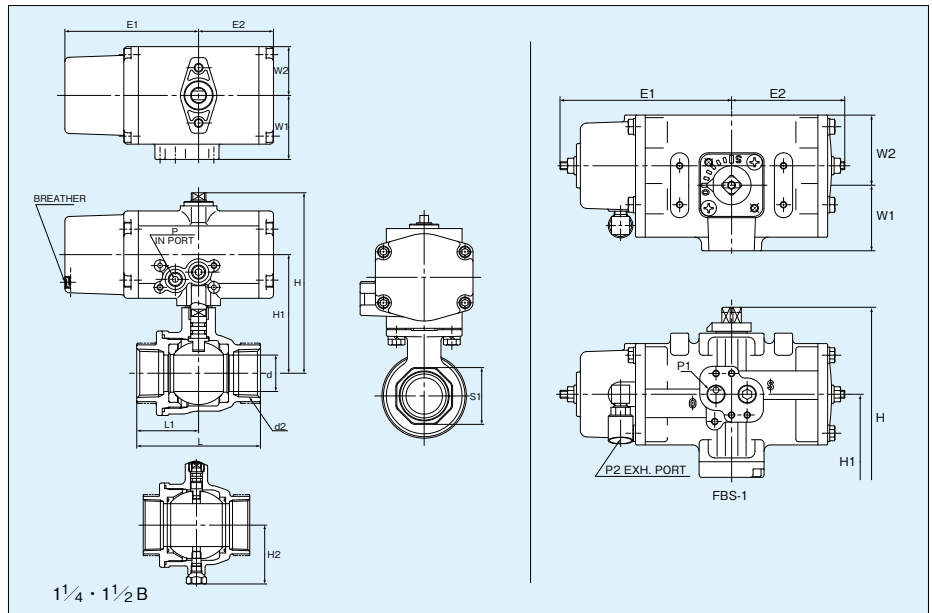

Dimensions

Valve Size (inch)	d	d ₂	H	H ₁	H ₂	L	L ₁	S ₁	Actuators						
									E ₁	E ₂	W ₁	W ₂	P ₁	P ₂	Type
1/2	15	Rc1/2	116	74	—	62	31	26	92	51.4	44	33.5	—	Rc1/8	CS-2
3/4	20	Rc3/4	178	108	—	73	36.5	32							
1	25	Rc1	182	112	—	85	42.5	39	132	87	50	54	Rc1/4	Rc1/8	FBS-1
1 1/4	32	Rc1 1/4	196	126	55	98	49	48							
1 1/2	40	Rc1 1/2	202	132	61	108	54	54							

(mm)

Types C-CS/FBS

Type C Pneumatic Actuators/Class 10K Stainless Steel Ball Valves, with Gland

Fig. **C-UTGE**
(Reduced bore)

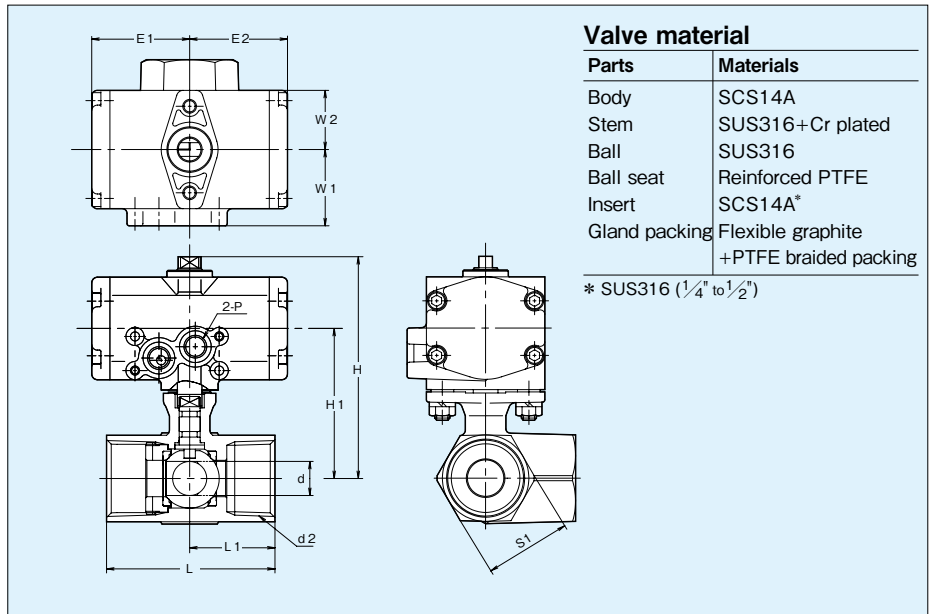

Valve material

Parts	Materials
Body	SCS14A
Stem	SUS316+Cr plated
Ball	SUS316
Ball seat	Reinforced PTFE
Insert	SCS14A*
Gland packing	Flexible graphite +PTFE braided packing

* SUS316 (1/4" to 1/2")

Dimensions

Valve Size (inch)	d	d ₂	H	H ₁	L	L ₁	S ₁	Actuators							
								E ₁	E ₂	W ₁	W ₂	P	Type		
1/4	4.5	Rc1/4	105.5	74	44	21	21								
3/8	6.8	Rc3/8	105.5	74	44	21	21	43	43	34.5	26	Rc1/8	C-1		
1/2	9.2	Rc1/2	124.5	82	56.5	27.5	25								
3/4	12.5	Rc3/4	127.5	85	59	30	32	51.4	51.4	44	33.5	Rc1/8	C-2		
1	16	Rc1	130.5	88	71	36	38								

(mm)

Type CS/FBS Pneumatic Actuators/Class 10K Stainless Steel Ball Valves, with Gland

Fig. **CS-UTGE**
Valve size: 1/4" to 3/8"
FBS-UTGE
Valve size: 1/2" to 1"
(Reduced bore)

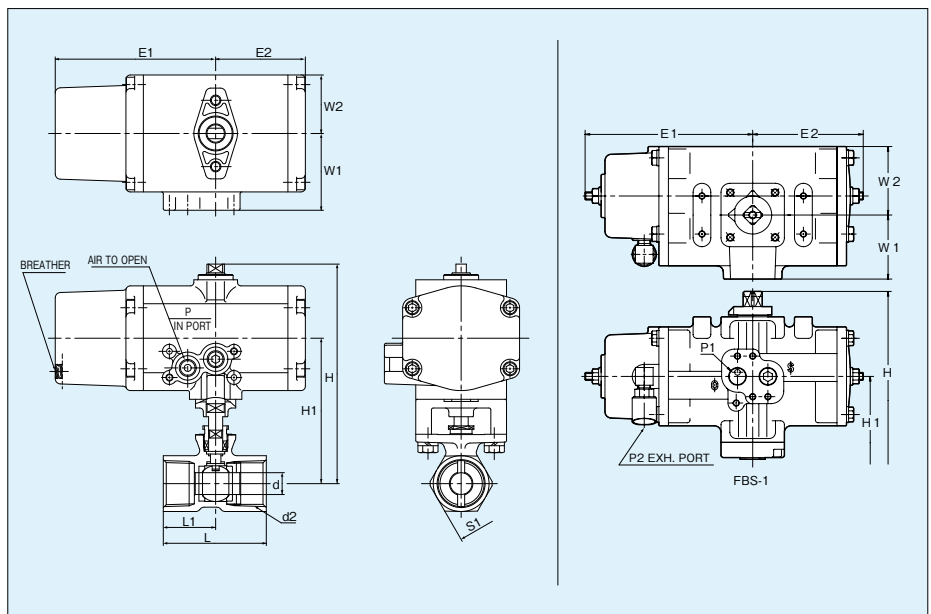

Dimensions

Valve Size (inch)	d	d ₂	H	H ₁	L	L ₁	S ₁	Actuators							
								E ₁	E ₂	W ₁	W ₂	P ₁	P ₂	Type	
1/4	4.5	Rc1/4	124.5	82	44	21	21								
3/8	6.8	Rc3/8	124.5	82	44	21	21	92	51.4	44	33.5	—	Rc1/8	CS-2	
1/2	9.2	Rc1/2	180.7	110.7	56.5	27.5	25								
3/4	12.5	Rc3/4	183.2	113.2	59	30	32	132	87	50	54	Rc1/4	Rc1/8	FBS-1	
1	16	Rc1	186.4	116.4	71	36	38								

(mm)

Type C Pneumatic Actuators/Class 10K Horizontal 3-way stainless steel Ball Valve

Fig. **C-UTNE**

(Reduced bore)

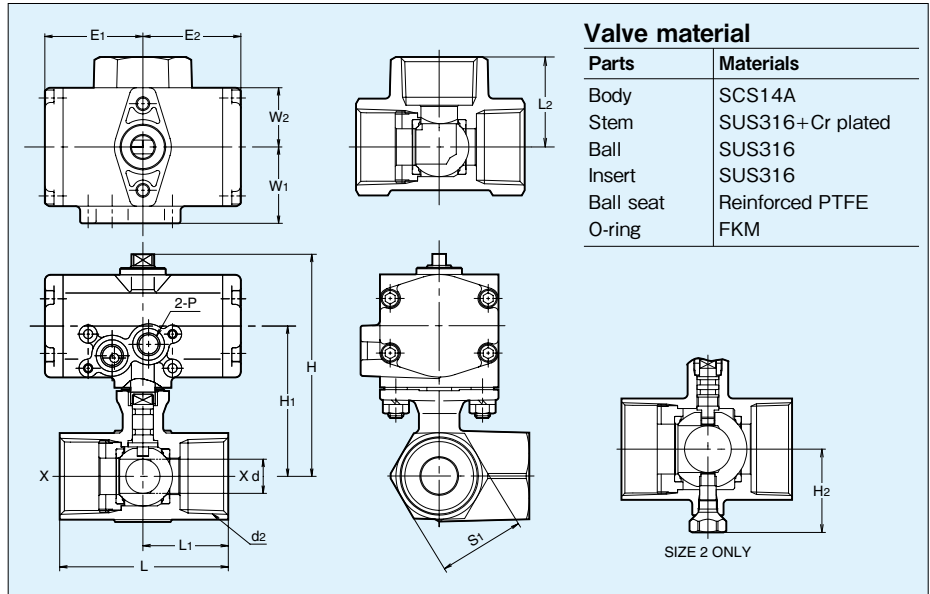

Note: Refer page 5 for flow directional forms.

Products are adequately identified with nameplates indicating either one Form1 or Form2

(mm)

Dimensions

Valve Size (inch)	d	d ₂	H	H ₁	H ₂	L	L ₁	S ₁	Actuator					
									E ₁	E ₂	W ₁	W ₂	P	Type
1/4	4.5	Rc1/4	85	53.5	—	44	21	21	43	43	34.5	26	Rc1/8	C-1
3/8	6.8	Rc3/8	85	53.5	—	44	21	21						
1/2	8.5	Rc1/2	90	58.5	—	58	29	25						
3/4	11.5	Rc3/4	94	62.5	—	61.5	31.5	32						
1	15	Rc1	97.5	66	—	74	37.5	38	51.4	51.4	44	33.5	Rc1/8	C-2
1 1/4	18	Rc1 1/4	128	85.5	—	82.5	41.5	49						
1 1/2	23	Rc1 1/2	131	88.5	—	90.5	44.5	53						
2	30	Rc2	137	94.5	53.5	109.5	54	65						

Type CS/FBS Pneumatic Actuators/Class 10K Horizontal 3-way stainless steel Ball Valve

Fig. **CS-UTNE**

Valve size: 1/4" to 1"

FBS-UTNE

Valve size: 1/4" to 2" (Reduced bore)

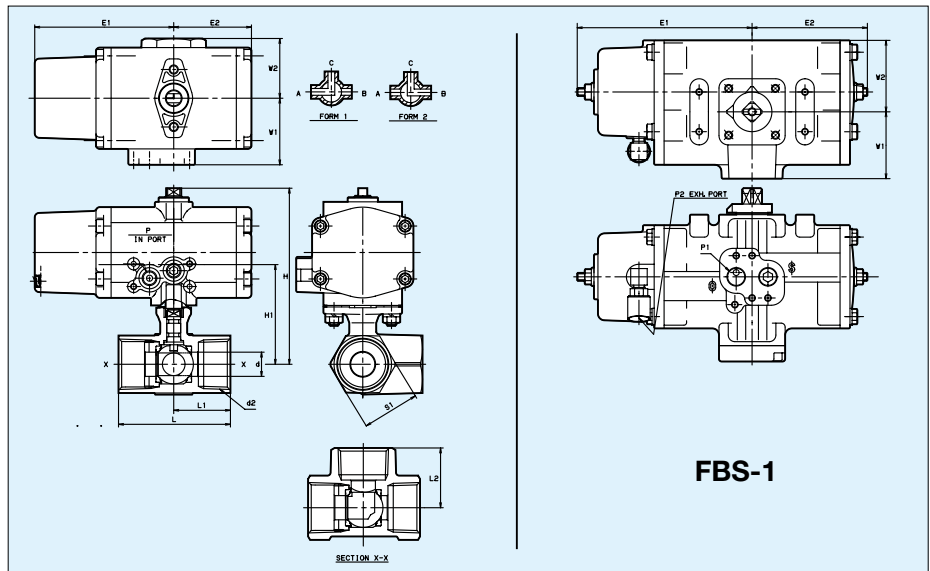

Note: Refer page 5 for flow directional forms.

Products are adequately identified with nameplates indicating either one Form1 or Form2

(mm)

Dimensions

Valve Size (inch)	d	d ₂	H	H ₁	H ₂	L	L ₁	L ₂	S ₁	Actuator					
										E ₁	E ₂	W ₁	W ₂	P	Type
1/4	4.5	Rc1/4	85	53.5	—	44	21	23	21	69.5	43	34.5	26	Rc1/8	CS-1
3/8	6.8	Rc3/8	85	53.5	—	44	21	23	21						
1/2	8.5	Rc1/2	109	66.5	—	58	29	29	25						
3/4	11.5	Rc3/4	113	70.5	—	61.5	31.5	33	32						
1	15	Rc1	116.5	74	—	74	37.5	39.5	38	92	51.4	44	33.5	Rc1/8	CS-2
1 1/4	18	Rc1 1/4	185.5	116.5	—	82.5	41.5	48	49						
1 1/2	23	Rc1 1/2	188.5	119.5	—	90.5	44.5	54	53						
2	30	Rc2	194.5	125.5	53.5	109.5	54	65	65						
										132	87	50	54	Rc1/4	FBS-1

Type C Pneumatic Actuators/Class 5K/10K Wafer Stainless Steel Ball Valves

Fig. C-5/10UTWE
(Full bore)

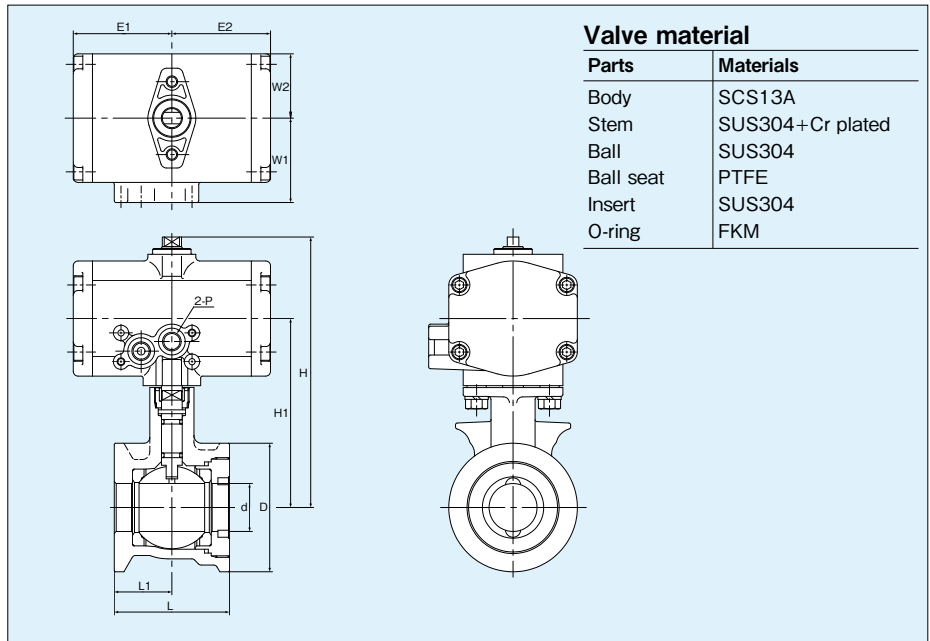

Valve material

Parts	Materials
Body	SCS13A
Stem	SUS304+Cr plated
Ball	SUS304
Ball seat	PTFE
Insert	SUS304
O-ring	FKM

Dimensions

Valve Size (inch)	d	H	H ₁	L	L ₁	D		Actuators					
						5UTWE	10UTWE	E ₁	E ₂	W ₁	W ₂	P	Type
3/8	10	114.5	83	35	17.5	43	48	43	43	34.5	26	Rc 1/8	C-1
1/2	15	117.5	86	40	20	48	53	51.4	51.4	44	33.5	Rc 1/8	C-2
3/4	20	138.5	96	50	25	53	58						
1	25	146.5	104	60	30	63	69						

(mm)

Type CS/FBS Pneumatic Actuators/Class 5K/10K Wafer Stainless Steel Ball Valves

Fig. CS-5/10UTWE

Valve size: 3/8" to 1/2"

FBS-5/10UTWE

Valve size: 3/4" to 1" (Full bore)

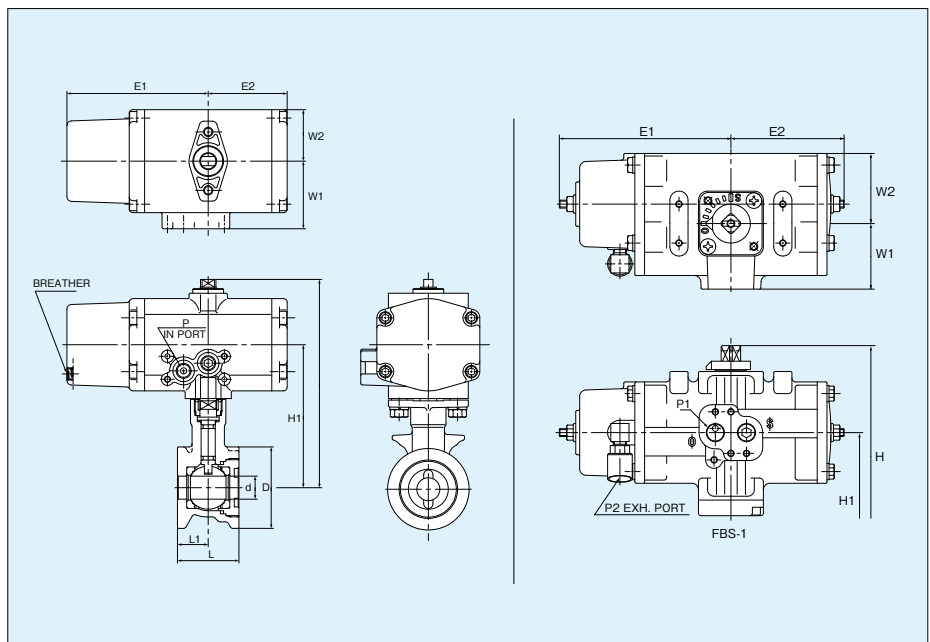

Dimensions

Valve Size (inch)	d	H	H ₁	L	L ₁	D		Actuators						
						5UTWE	10UTWE	E ₁	E ₂	W ₁	W ₂	P ₁	P ₂	Type
3/8	10	133.5	91	35	17.5	43	48	92	51.4	44	33.5	-	Rc 1/8	CS-2
1/2	15	136.5	94	40	20	48	53	132	87	50	54	Rc 1/4	Rc 1/8	FBS-1
3/4	20	196	126	50	25	53	58							
1	25	204	134	60	30	63	69							

(mm)

Type C Pneumatic Actuators/Class 10K Long Neck stainless steel Ball Valve

Fig. C-UTKLAHE

(Reduced bore)

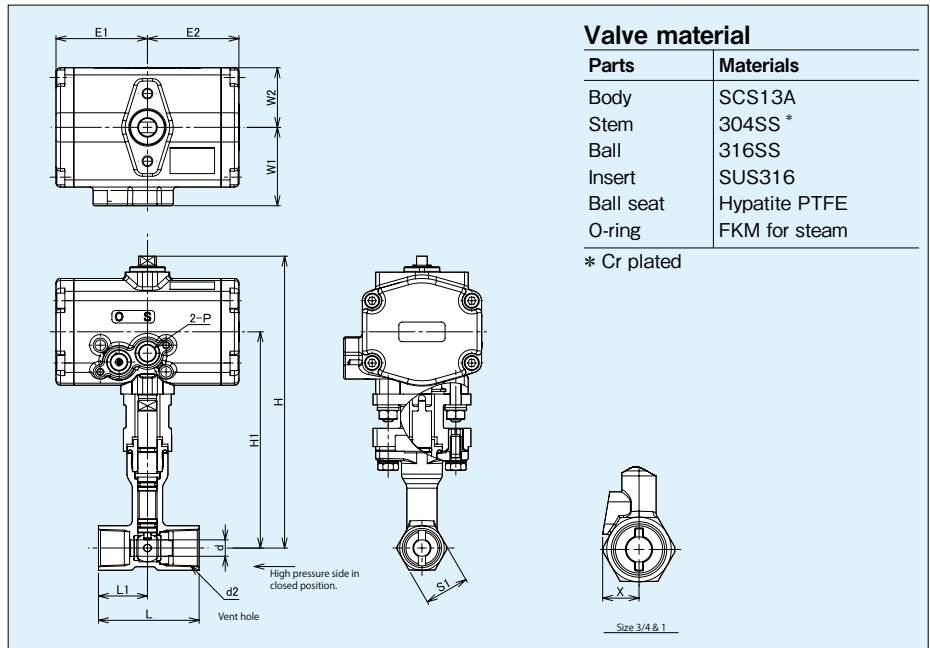

Valve material

Parts	Materials
Body	SCS13A
Stem	304SS *
Ball	316SS
Insert	SUS316
Ball seat	Hypatite PTFE
O-ring	FKM for steam

* Cr plated

Dimensions

Valve Size (inch)	d	d ₂	H	H ₁	L	L ₁	S ₁	X	Actuator					
									E ₁	E ₂	W ₁	W ₂	P	Type
1/2	9.2	Rc1/2	164	121.5	56.5	275	25	—	51.4	51.4	4.4	33.5	Rc1/8	C-2
3/4	12.5	Rc3/4	166.5	124	59	30	32	18						
1	16	Rc1	172	129.5	71	36	38	21.5						

(mm)

Type CS/FBS Pneumatic Actuators/Class 10K Long Neck stainless steel Ball Valve

Fig. CS-UTKLAHE

Valve size: 1/2" to 1"

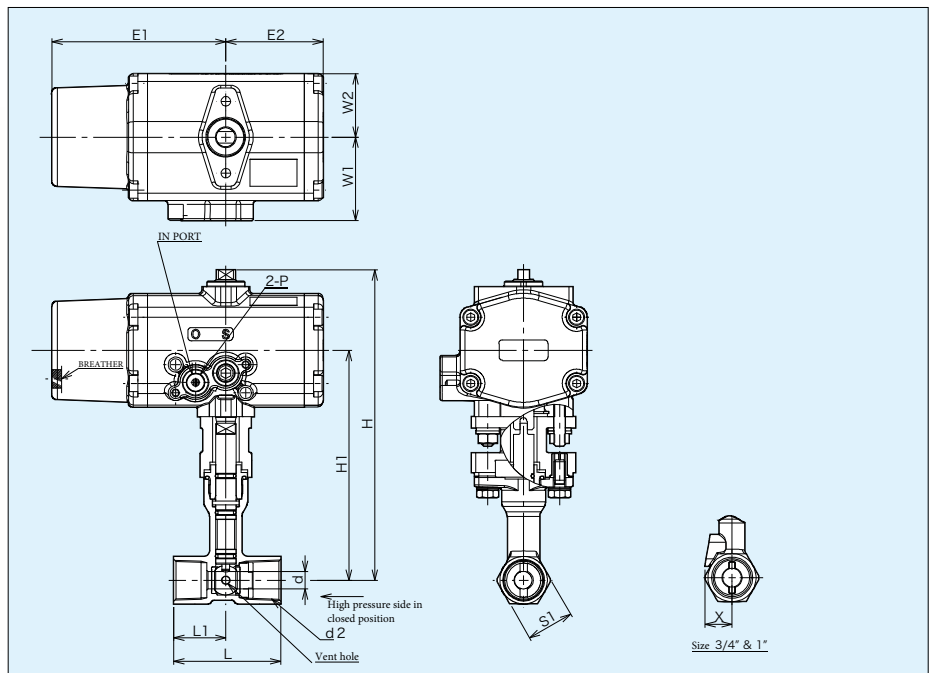

Dimensions

Valve Size (inch)	d	d ₂	H	H ₁	L	L ₁	L ₁	X	S ₁	Actuator						
										E ₁	E ₂	W ₁	W ₂	P ₁	P ₂	Type
1/2	9.2	Rc1/2	164	121.5	56.5	27.5	27.5	—	25	92	51.4	44	33.5	—	Rc1/8	CS-2
3/4	12.5	Rc3/4	166.5	124	59	39	39	18	32							
1	16	Rc1	172	129.5	71	36	36	21.5	38							

(mm)

Precautions for Trouble-free Operation of Pneumatic Actuator Driven Ball Valves

Storage and Handling

Pneumatically operated KITZ compact ball valves are individually packed in Styrofoam boxes. Do NOT unpack until you are ready to mount on the pipeline. Store in dry, corrosion-free environment to keep rust-free, although they are adequately coated for primary protection. Handle units carefully when actuators are equipped with solenoid valves and other accessories. Do NOT place any other objects on actuators, and do NOT step on actuators. Overloading actuators must always be prevented.

Mounting and Piping

Before mounting pneumatically operated KITZ compact ball valves, make visual inspection of all valves, actuators and accessories to assure trouble-free condition. Tighten any loosened bolts securely. Clean valve and pipe bores to remove welding spatters, scales or any other foreign objects which may have been left inside. After mounting has been completed, air blow the inside of all connected pipes and valves prior to the pilot operation of the system.

Do NOT use where corrosive gas, chemical liquids, sea water cause contamination. Exposed rotating parts, such as the actuator shaft, must be protected from water or rainfall. They are not designed whether-proof.

Threading pipes or nipples on actuators must be maximized to five rotations, so that over-tightening threads may not develop cracks in die-cast aluminum housing, and cause air leakage and operational difficulty to actuators (Recommended tightening torque : 10 N-m for Rc 1/8" 15 N-m Rc 1/4"). Type CS spring return actuators should be mounted so that the exhaust hole on the cylinder, faces downwards at times (See the below) or, when unavoidable, the hole must be protected by adequate water-prevention measures.

KITZ compact ball valves can be mounted on KITZ Type C or CS actuators either horizontally, vertically or at any angle depending on your piping or operational convenience. However, filter-regulators must be mounted always horizontally, using amounting bracket.

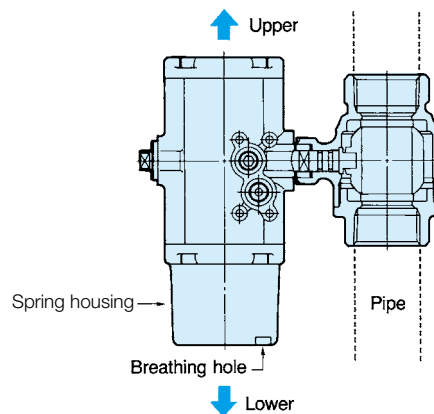

Operation

Pneumatically operated KITZ compact ball valves are designed to be driven by air pressure ranging from 0.4 MPa to 0.7 MPa (60 to 100 psi). Smaller or larger air pressure will result in malfunction. We recommend to employ 0.4 MPa (60 psi), our standard operating pressure.

Be sure to dry and filter the air supply for trouble-free operation. This is particularly important in cold and humid climates.

Maintenance

Pneumatically operated KITZ compact ball valves are lubrication-free. When a leakage is detected on the actuator after a few years of operation, we recommended the actuator be disassembled to detect wear or deformation of sealers such as O-rings and gaskets for possible replacement.

MEMO

A large grid of dashed lines for taking notes, consisting of 20 columns and 30 rows.

MEMO

A large grid of dashed lines for taking notes, consisting of 20 columns and 25 rows.

MEMO

A large grid of dashed lines for taking notes, consisting of 20 columns and 30 rows.

CAUTION

Pressure-temperature ratings and other performance data published in this catalog have been developed from our design calculation, in-house testing, field reports provided by our customers and/or published official standards or specifications. They are good only to cover typical applications as a general guideline to users of KITZ products introduced in this catalog.

For any specific application, users are kindly requested to contact KITZ Corporation for technical advice, or to carry out their own study and evaluation for proving suitability of these products to such an application. Failure to follow this request could result in property damage and/or personal injury, for which we shall not be liable.

While this catalog has been compiled with the utmost care, we assume no responsibility for errors, impropriety or inadequacy. Any information provided in this catalog is subject to from-time-to-time change without notice for error rectification, product discontinuation, design modification, new product introduction or any other cause that KITZ Corporation considers necessary. This edition cancels all previous issues.

Read instruction manual carefully before use.

NOTICE

If any products designated as strategic material in the Foreign Exchange and Foreign Trade Law, Cabinet Order Concerning Control of Export Trade, Cabinet Order Concerning Control of Foreign Exchange and other related laws and ordinances ("Foreign Exchange Laws") are exported to any foreign country or countries, an export license issued by the Japanese Government will be required under the Foreign Exchange Laws.

Further, there may be cases where an export license issued by the government of the United States or other country will be required under the applicable export-related laws and ordinances in such relevant countries.

The contract shall become effective subject to that a relevant export license is obtained from the Japanese Government.

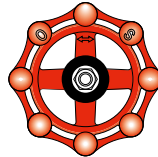

*A chrysanthemum-handle is a symbol of KITZ,
the brand of valve reliability*

ISO 9001 certified since 1989

KITZ
KITZ CORPORATION

Tokyo Shiodome Building,
1-9-1, Higashi-Shimbashi, Minato-ku, Tokyo 105-7305, Japan
Building Facilities and Machinery Equipment Business Unit/Industrial Business Unit
International Sales Department
Phone : +81-50-3649-2202
URL : <https://www.kitz.com/en/>

— Distributed by —